

# 1N6120A

## Transient Voltage Suppressors

Pppm: 500W



### FEATURE

Low power loss  
High surge capability  
Glass passivated chip junction  
High temperature soldering guaranteed  
260°C/10sec/0.375" lead length at 5 lbs tension

### MECHANICAL DATA

Terminal: Plated axial leads solderable per J-STD-002  
Polarity: no marking  
Mounting position: any

### SOD-64E

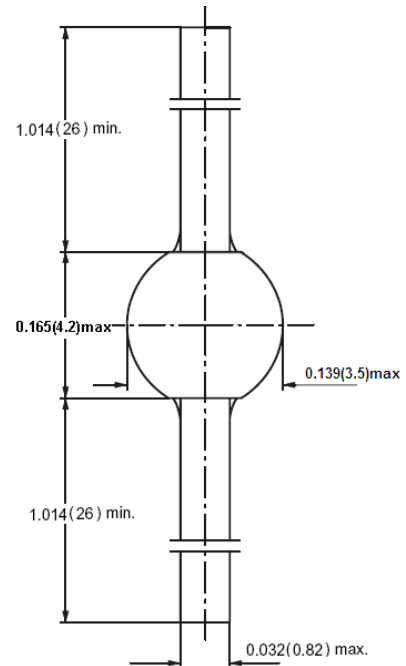

Dimensions in inches and (millimeters)

### MAXIMUM RATINGS (TA = 25 °C unless otherwise noted)

PARAMETER	SYMBOL	1N6120A	units
Peak power dissipation with a 10/1000 $\mu$ s waveform (1) (Fig. 1)	P <sub>PPM</sub>	500	W
Peak pulse current with a 10/1000 $\mu$ s waveform (1)	I <sub>PPM</sub>	9.3	A
Breakdown Voltage at I <sub>T</sub> =30mA	V <sub>BR</sub>	37.1min 41.0max	V
Maximum Reverse Leakage at V <sub>WM</sub> =29.7V	I <sub>R</sub>	1.0	$\mu$ A
Maximum Clamping Voltage at I <sub>PPM</sub>	V <sub>C</sub>	53.6	V
Power dissipation on infinite heatsink at T <sub>L</sub> = 75 °C (Fig. 5)	P <sub>D</sub>	5.0	W
Typical thermal resistance junction-to-lead	R <sub>th(jl)</sub>	20	°C/W
Typical thermal resistance junction-to--ambient	R <sub>th(ja)</sub>	75	°C/W
Storage and Operating Junction Temperature	T <sub>stg</sub> , T <sub>j</sub>	-55 to +175	°C

Note:  
(1) Non-repetitive current pulse, per Fig. 3 and derated above TA = 25 °C per Fig. 2

## RATINGS AND CHARACTERISTIC CURVES 1N6120A

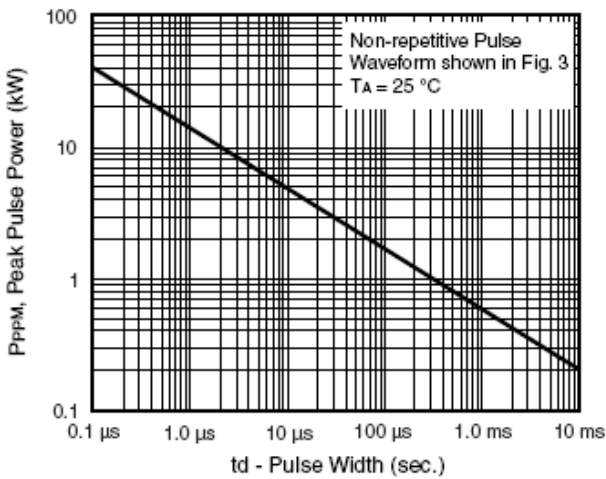

Figure 1. Peak Pulse Power Rating Curve

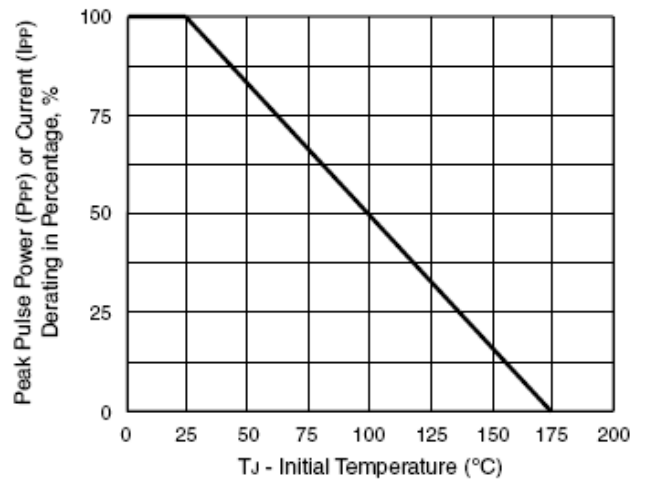

Figure 2. Pulse Power or Current versus Initial Junction Temperature

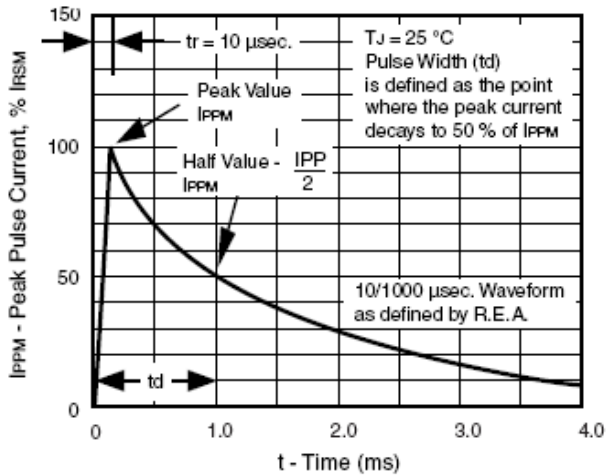

Figure 3. Pulse Waveform

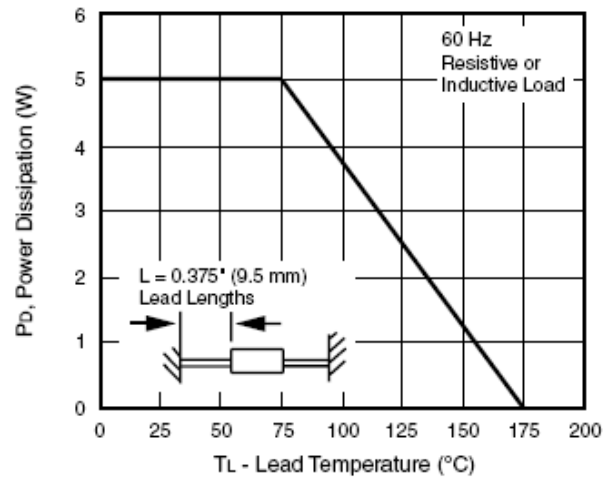

Figure 4. Power Derating Curve

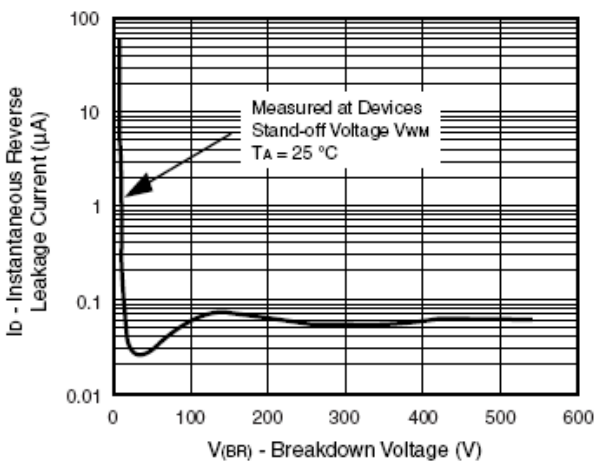

Figure 5. Typical Reverse Leakage Characteristics

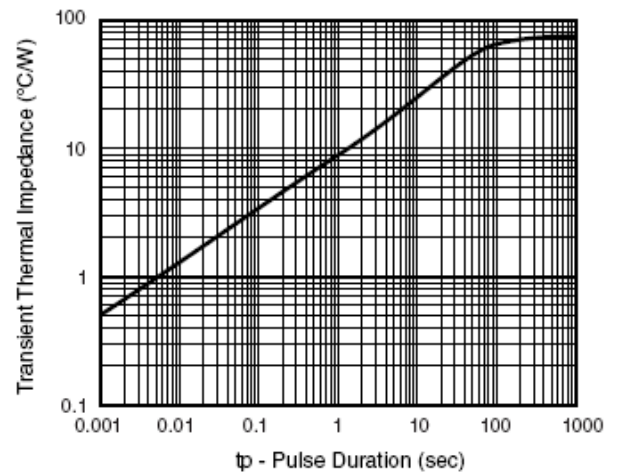

Figure 6. Typical Transient Thermal Impedance