

1N5617

SINTERED GLASS JUNCTION FAST AVALANCHE RECTIFIER

VOLTAGE: 400V

CURRENT: 1.0A



FEATURE

Glass passivated
Hermetically sealed package
Low reverse current
Soft recovery characteristics

MECHANICAL DATA

Case: SOD-57 sintered glass case
Terminal: Plated axial leads solderable per MIL-STD 202E, method 208C
Polarity: color band denotes cathode end
Mounting position: any

SOD-57

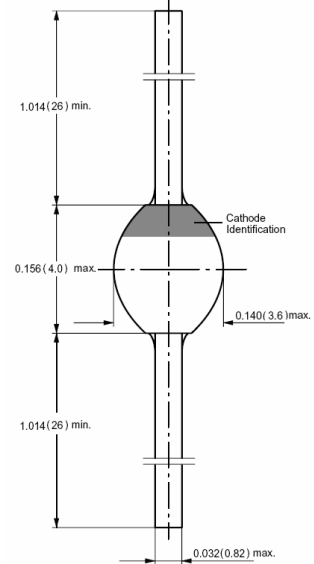

Dimensions in inches and (millimeters)

MAXIMUM RATINGS AND ELECTRICAL CHARACTERISTICS

(single-phase, half-wave, 60HZ, resistive or inductive load rating at 25°C, unless otherwise stated)

	SYMBOL	1N5617	units
Maximum Recurrent Peak Reverse Voltage	V_{RRM}	400	V
Maximum RMS Voltage	V_{RMS}	280	V
Maximum DC blocking Voltage	V_{DC}	400	V
Maximum Reverse Breakdown Voltage $I_R=50\mu A$	V_{BR}	440	V
Maximum Average Forward Rectified Current 3/8" lead length at $T_a=55^\circ C$	I_{FAV}	1.0	A
Peak Forward Surge Current 8.3ms single half sine-wave superimposed on rated load	I_{FSM}	25	A
Maximum Forward Voltage at Forward Current 3.0A and 25°C	V_F	1.6	V
Maximum DC Reverse Current $T_a=25^\circ C$ at rated DC blocking voltage $T_a=100^\circ C$	I_R	1.0 25.0	μA
Maximum Reverse Recovery Time (Note 1)	T_{rr}	150	nS
Typical Junction Capacitance (Note 2)	C_j	35.0	pF
Typical Thermal Resistance (Note 3)	$R_{th(ja)}$	45.0	$^\circ C / W$
Storage and Operating Junction Temperature	T_{stg}, T_j	-65 to +175	$^\circ C$

Note:

1. Reverse Recovery Condition $I_f = 0.5A, I_r = 1.0A, I_{rr} = 0.25A$
2. Measured at 1.0 MHz and applied reverse voltage of 12.0Vdc
3. Thermal Resistance from Junction to Ambient at 3/8" lead length, P.C. Board Mounted

RATINGS AND CHARACTERISTIC CURVES 1N5617

FIG. 1 - FORWARD CURRENT DERATING CURVE

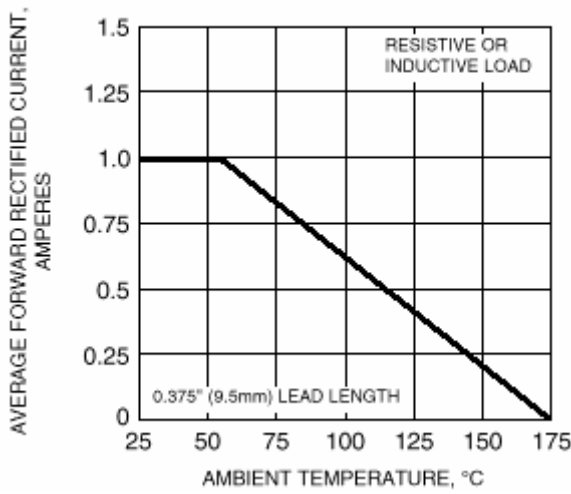

FIG. 2 - MAXIMUM NON-REPETITIVE PEAK FORWARD SURGE CURRENT

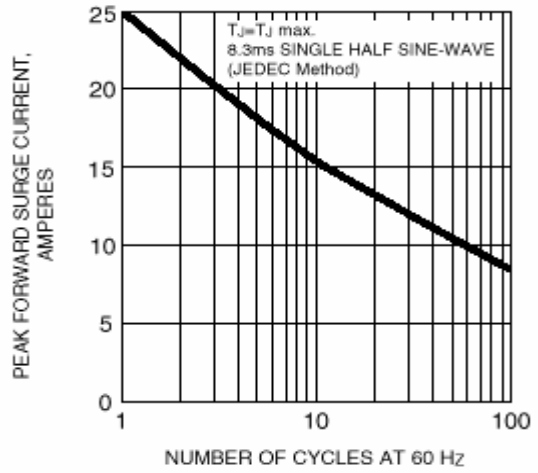

FIG. 3 - TYPICAL INSTANTANEOUS FORWARD CHARACTERISTICS

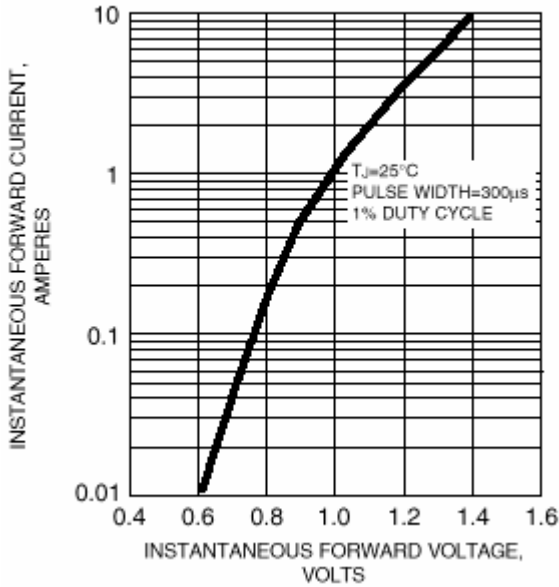

FIG. 4 - TYPICAL REVERSE CHARACTERISTICS

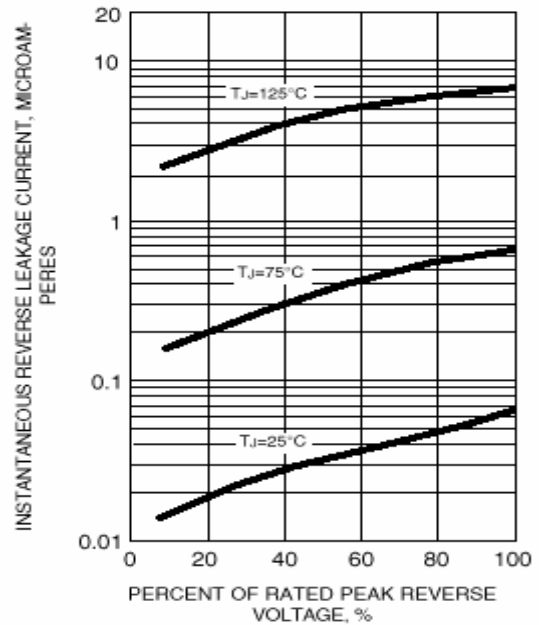

FIG. 5 - TYPICAL JUNCTION CAPACITANCE

