

BYM26E

SINTERED GLASS JUNCTION FAST AVALANCHE RECTIFIER

VOLTAGE: 1000V

CURRENT: 2.3A



FEATURE

Glass passivated
High maximum operating temperature
Low leakage current
Excellent stability
Guaranteed avalanche energy absorption capability

MECHANICAL DATA

Case: SOD-64 sintered glass case
Terminal: Plated axial leads solderable per MIL-STD 202E, method 208C
Polarity: color band denotes cathode end
Mounting position: any

SOD-64

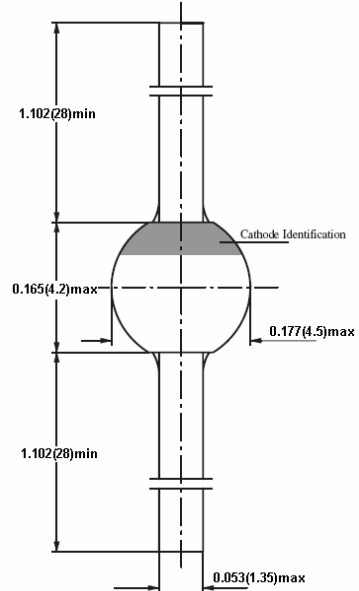

Dimensions in millimeters

MAXIMUM RATINGS AND ELECTRICAL CHARACTERISTICS

(single-phase, half-wave, 60HZ, resistive or inductive load rating at 25°C, unless otherwise stated)

	SYMBOL	BYM26E	units
Maximum Recurrent Peak Reverse Voltage	V_{RRM}	1000	V
Maximum RMS Voltage	V_{RMS}	700	V
Maximum DC blocking Voltage	V_{DC}	1000	V
Reverse Breakdown Voltage at $I_R = 0.1mA$	$V_{(BR)R}$	1100min	V
Maximum Average Forward Rectified Current and $T_{tp}=55^{\circ}C$; lead length=10mm	I_{FAV}	2.3	A
Peak Forward Surge Current at $t=10ms$ half sine wave	I_{FSM}	45	A
Maximum Forward Voltage at Rated Forward Current and 25°C $I_F = 2.0A$	V_F	2.65	V
Maximum DC Reverse Current $T_a = 25^{\circ}C$ at rated DC blocking voltage $T_a = 150^{\circ}C$	I_R	10 150	μA μA
Maximum Reverse Recovery Time (Note 1)	T_{rr}	75	nS
Non Repetitive Reverse Avalanche Energy	E_R	10	mJ
Diode Capacitance at $f=1MHz, V_R=0V$	C_d	75	pF
Typical Thermal Resistance (Note 2)	$R_{th(ja)}$	75	K/W
Storage and Operating Junction Temperature	T_{stg}, T_j	-65 to +175	$^{\circ}C$

Note:

- Reverse Recovery Condition $I_F = 0.5A, I_R = 1.0A, I_{RR} = 0.25A$
- Device mounted on an epoxy-glass printed-circuit board, 1.5mm thick; thickness of Cu-layer $\geq 40 \mu m$

Rev.A1, 20-Nov-07

<https://www.voltaristech.com/>

RATINGS AND CHARACTERISTIC CURVES BYM26E

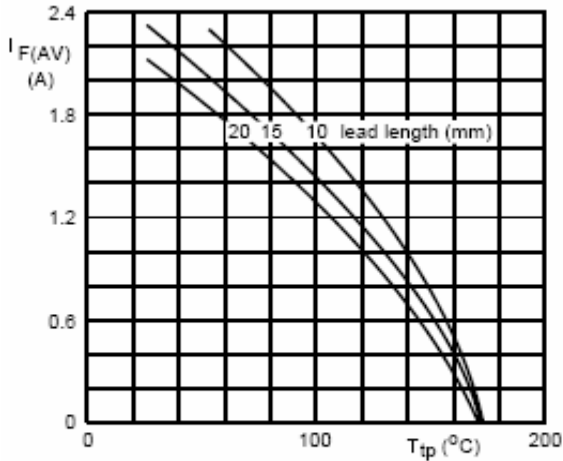

Fig. 1 Maximum average forward current as a function of tie-point temperature (including losses due to reverse leakage).

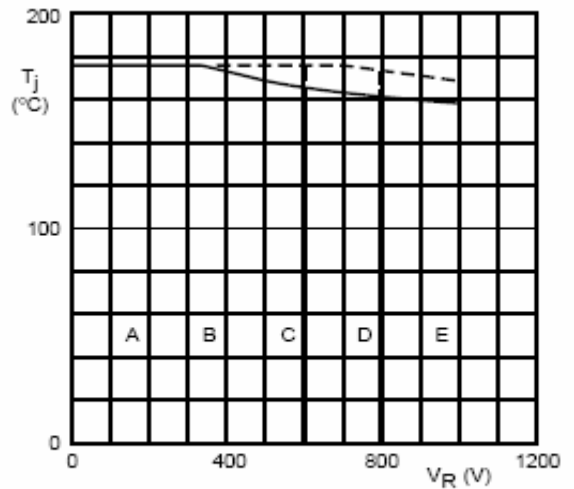

Fig. 2 Maximum permissible junction temperature as a function of reverse voltage.

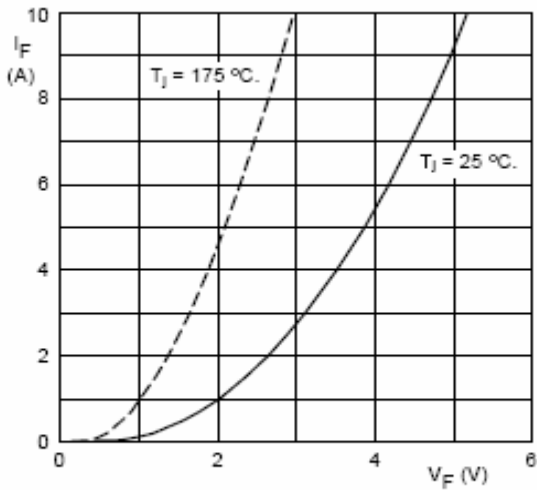

Fig. 3 Forward current as a function of forward voltage; maximum values.

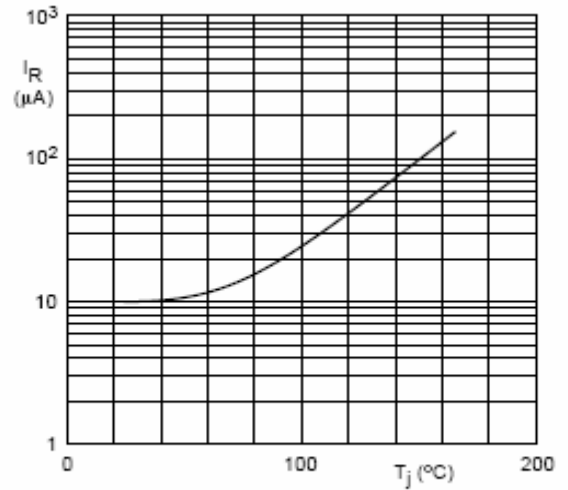

Fig. 4 Reverse current as a function of junction temperature; maximum values.

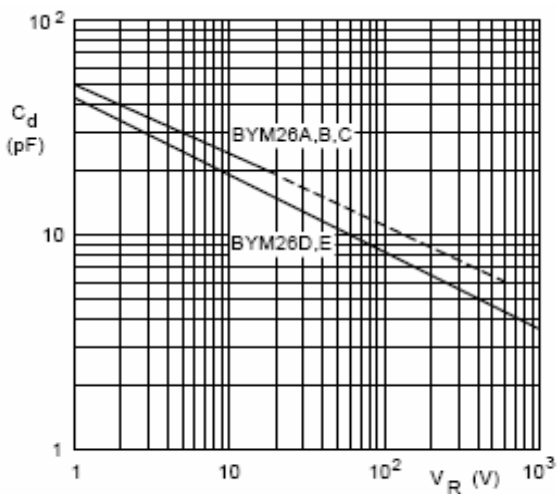

Fig. 5 Diode capacitance as a function of reverse voltage; typical values.