

BYM36C

SINTERED GLASS JUNCTION FAST AVALANCHE RECTIFIER

VOLTAGE: 600V

CURRENT: 3.0A



FEATURE

Glass passivated
High maximum operating temperature
Low leakage current
Excellent stability
Guaranteed avalanche energy absorption capability

MECHANICAL DATA

Case: SOD-64 sintered glass case
Terminal: Plated axial leads solderable per MIL-STD 202E, method 208C
Polarity: color band denotes cathode end
Mounting position: any

SOD-64

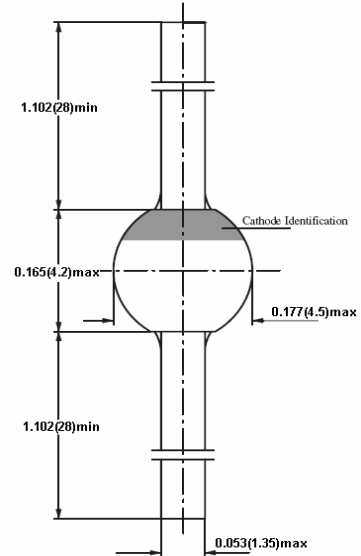

Dimensions in inches and (millimeters)

MAXIMUM RATINGS AND ELECTRICAL CHARACTERISTICS

(single-phase, half-wave, 60HZ, resistive or inductive load rating at 25°C, unless otherwise stated)

	SYMBOL	BYM36C	units
Maximum Recurrent Peak Reverse Voltage	V_{RRM}	600	V
Maximum RMS Voltage	V_{RMS}	420	V
Maximum DC blocking Voltage	V_{DC}	600	V
Reverse avalanche breakdown voltage at $I_R = 0.1 \text{ mA}$	$V_{(BR)R}$	700min	V
Maximum Average Forward Rectified Current 3/8" lead length at $T_{tp} = 55^\circ\text{C}$	I_{FAV}	3.0	A
Peak Forward Surge Current at $T_p = 10\text{ms}$ half sinewave	I_{FSM}	65	A
Maximum Forward Voltage at rated Forward Current	V_F	1.60	V
Non-repetitive peak reverse avalanche energy (Note 1)	E_{RSM}	10	mJ
Maximum DC Reverse Current at rated DC blocking voltage	I_R	5.0 150.0	μA
Maximum Reverse Recovery Time (Note 2)	T_{rr}	100	nS
Diode Capacitance (Note 3)	C_d	85	pF
Typical Thermal Resistance (Note 4)	$R_{th(ja)}$	75	$^\circ\text{C}/\text{W}$
Storage and Operating Junction Temperature	T_{stg}, T_j	-65 to +175	$^\circ\text{C}$

Note:

- $I_R = 400\text{mA}$; $T_j = T_{jmax}$ prior to surge; inductive load switched off
- Reverse Recovery Condition $I_f = 0.5\text{A}$, $I_r = 1.0\text{A}$, $I_{rr} = 0.25\text{A}$
- Measured at 1.0 MHz and applied reverse voltage of 0Vdc
- Device mounted on an epoxy-glass printed-circuit board, 1.5mm thick

RATINGS AND CHARACTERISTIC CURVES BYM36C

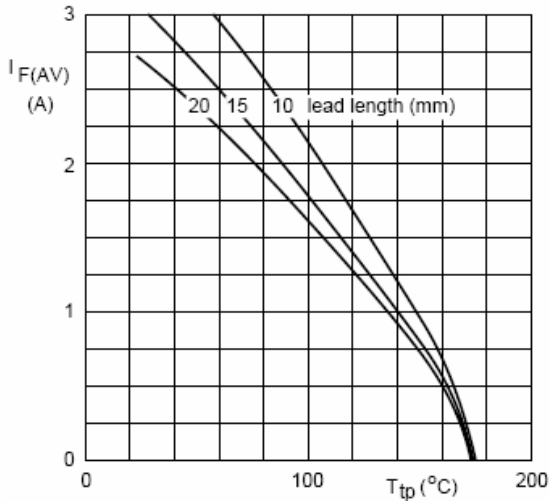

Fig. 1 Maximum average forward current as a function of tie-point temperature (including losses due to reverse leakage).

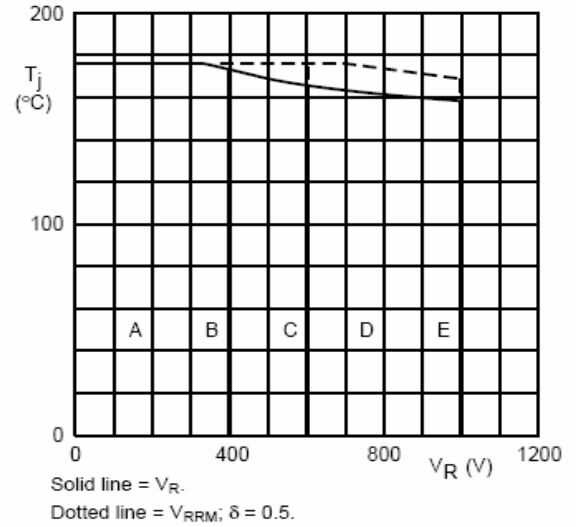
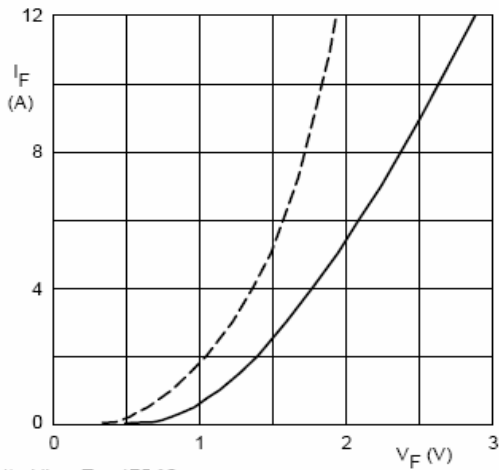

Fig. 2 Maximum permissible junction temperature as a function of reverse voltage.



Dotted line: $T_j = 175$ °C.
Solid line: $T_j = 25$ °C.

Fig. 3 Forward current as a function of forward voltage; maximum values.

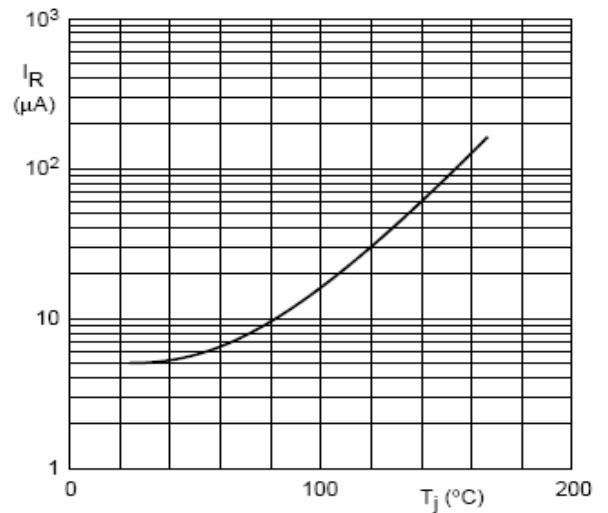
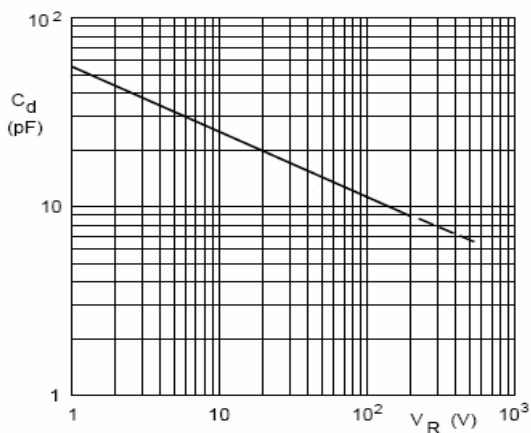

Fig. 4 Reverse current as a function of junction temperature; maximum values.



$f = 1$ MHz; $T_j = 25$ °C.

Fig. 5 Diode capacitance as a function of reverse voltage, typical values.