

BYT52A THRU BYT52M

SINTERED GLASS JUNCTION FAST AVALANCHE RECTIFIER

VOLTAGE: 50 TO 1000V

CURRENT: 1.4A



FEATURE

Glass passivated junction
Hermetically sealed package
Low reverse current
Soft recovery characteristics

MECHANICAL DATA

Case: SOD-57 sintered glass case
Terminal: Plated axial leads solderable per MIL-STD 202E, method 208C
Polarity: color band denotes cathode end
Mounting position: any

SOD-57

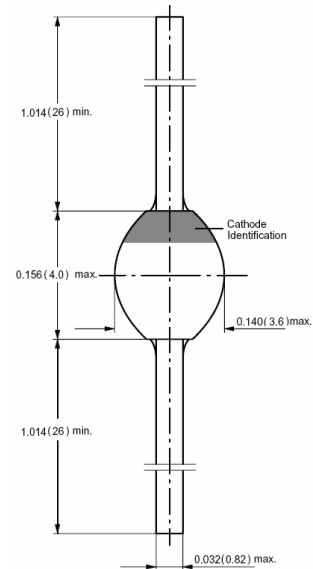

Dimensions in millimeters

MAXIMUM RATINGS AND ELECTRICAL CHARACTERISTICS

(single-phase, half-wave, 60HZ, resistive or inductive load rating at 25°C, unless otherwise stated)

	SYMBOL	BYT52 A	BYT52 B	BYT52 D	BYT52 G	BYT52 J	BYT52 K	BYT52 M	units
Maximum Recurrent Peak Reverse Voltage	V_{RRM}	50	100	200	400	600	800	1000	V
Maximum RMS Voltage	V_{RMS}	35	70	140	210	420	560	700	V
Maximum DC blocking Voltage	V_{DC}	50	100	200	400	600	800	1000	V
Maximum Average Forward Rectified Current at $I=10\text{mm}$	I_{FAV}	1.4							A
Peak Forward Surge Current at $T_p=10\text{ms}$ half sinewave	I_{FSM}	50.0							A
Maximum Forward Voltage at rated Forward Current and 25°C $I_f=1\text{A}$	V_F	1.30							V
Maximum DC Reverse Current $T_a=25^\circ\text{C}$ at rated DC blocking voltage $T_a=150^\circ\text{C}$	I_R	5.0 150							μA μA
Maximum Reverse Recovery Time (Note 1)	T_{rr}	200							nS
Non Repetitive Reverse Avalanche Energy at $I_{BR(R)}=0.4\text{A}$	E_R	-					10		mJ
Typical Thermal Resistance (Note 2)	R_{thJA}	100							K/W
Storage and Operating Junction Temperature	T_{stg}, T_j	-55 to +175							°C

Note:

- Reverse Recovery Condition $I_F=0.5\text{A}$, $I_R=1.0\text{A}$, $I_{RR}=0.25\text{A}$
- on P.C. board with spacing 20mm

RATINGS AND CHARACTERISTIC CURVES BYT52A THRU BYT52M

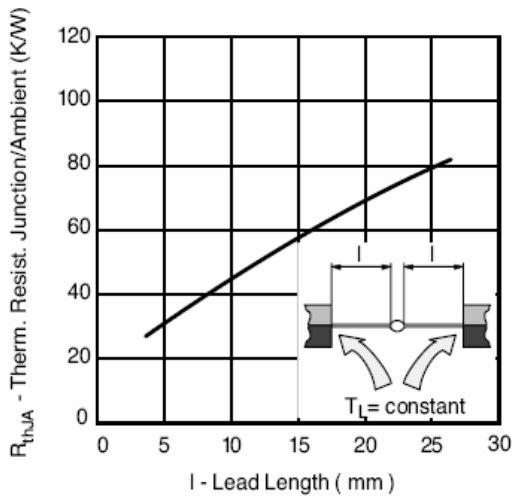

Figure 1. Max. Thermal Resistance vs. Lead Length

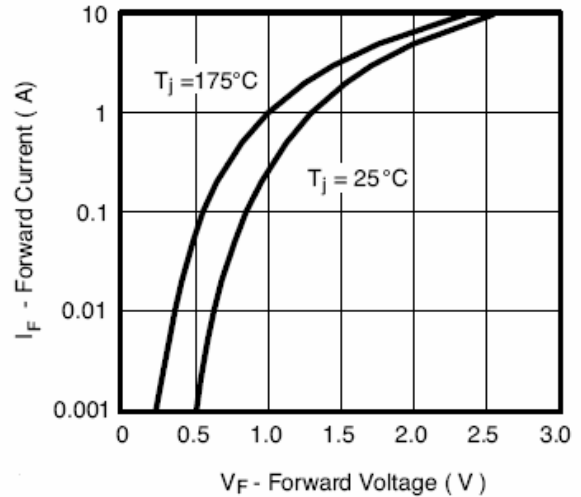

Figure 2. Forward Current vs. Forward Voltage

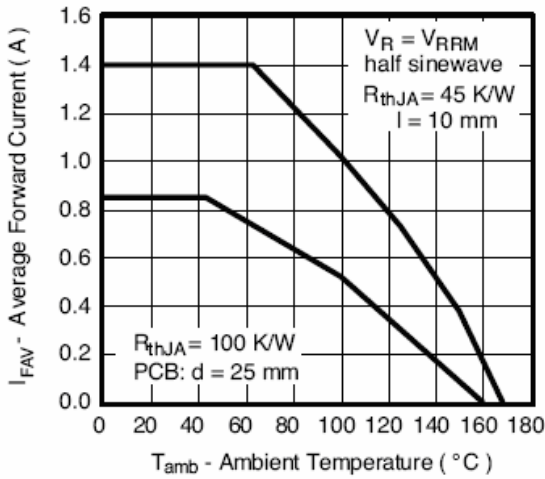

Figure 3. Max. Average Forward Current vs. Ambient Temperature

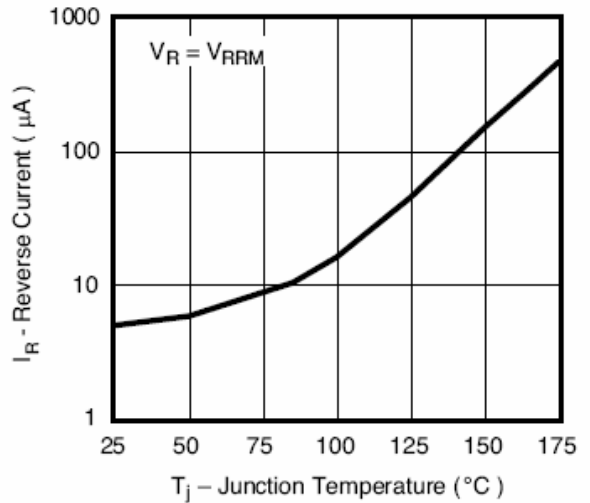

Figure 4. Reverse Current vs. Junction Temperature

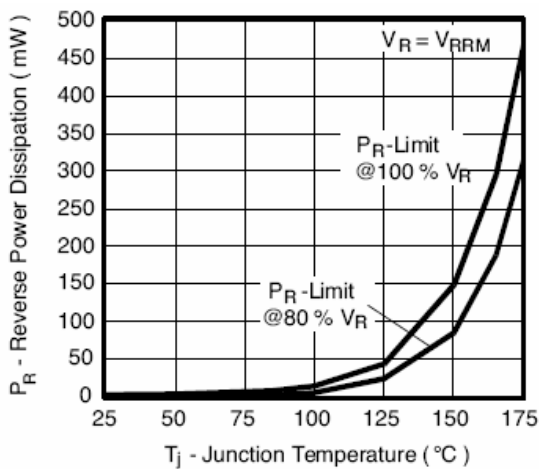

Figure 5. Max. Reverse Power Dissipation vs. Junction Temperature

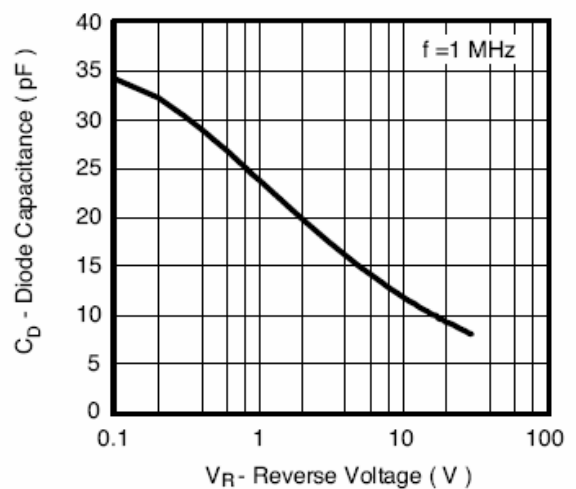

Figure 6. Diode Capacitance vs. Reverse Voltage