

BYT53A THRU BYT53G

ULTRAFAST AVALANCHE SINTERGLASS DIODE

VOLTAGE: 50 TO 400V

CURRENT: 1.9A



FEATURE

Glass passivated junction
Hermetically sealed package
Low reverse current
Soft recovery characteristics

MECHANICAL DATA

Case: SOD-57 sintered glass case
Terminal: Plated axial leads solderable per
MIL-STD 202E, method 208C
Polarity: color band denotes cathode end
Mounting position: any

SOD-57

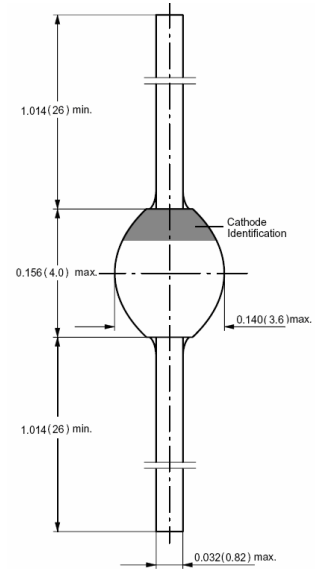

Dimensions in millimeters

MAXIMUM RATINGS AND ELECTRICAL CHARACTERISTICS

(single-phase, half-wave, 60HZ, resistive or inductive load rating at 25°C, unless otherwise stated)

	SYMBOL	BYT53 A	BYT53 B	BYT53 C	BYT53 D	BYT53 F	BYT53 G	units
Maximum Recurrent Peak Reverse Voltage	V_{RRM}	50	100	150	200	300	400	V
Maximum RMS Voltage	V_{RMS}	35	70	105	140	210	280	V
Maximum DC blocking Voltage	V_{DC}	50	100	150	200	300	400	V
Maximum Average Forward Rectified Current at $I=10\text{mm}$, $T_L=25^\circ\text{C}$	I_{FAV}	1.9						A
Peak Forward Surge Current at $T_p=10\text{ms}$ half sinewave	I_{FSM}	50.0						A
Maximum Forward Voltage at rated Forward Current and 25°C $I_f=1\text{A}$	V_F	1.10						V
Maximum DC Reverse Current at rated DC blocking voltage $T_a=25^\circ\text{C}$ $T_a=150^\circ\text{C}$	I_R	5.0 200						μA μA
Maximum Reverse Recovery Time (Note 1)	T_{rr}	50						nS
Non Repetitive Reverse Avalanche Energy $I_{BR(R)}=1\text{A}$	E_R	20						mJ
Typical Thermal Resistance (Note 2)	R_{thJA}	100						K/W
Storage and Operating Junction Temperature	T_{stg}, T_j	-55 to +175						$^\circ\text{C}$

Note:

- Reverse Recovery Condition $I_F=0.5\text{A}$, $I_R=1.0\text{A}$, $I_{RR}=0.25\text{A}$
- on P.C. board with spacing 20mm

RATINGS AND CHARACTERISTIC CURVES BYT53A THRU BYT53G

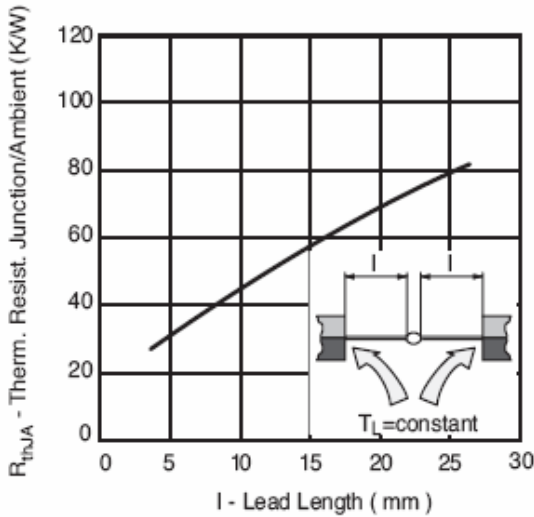

Figure 1. Max. Thermal Resistance vs. Lead Length

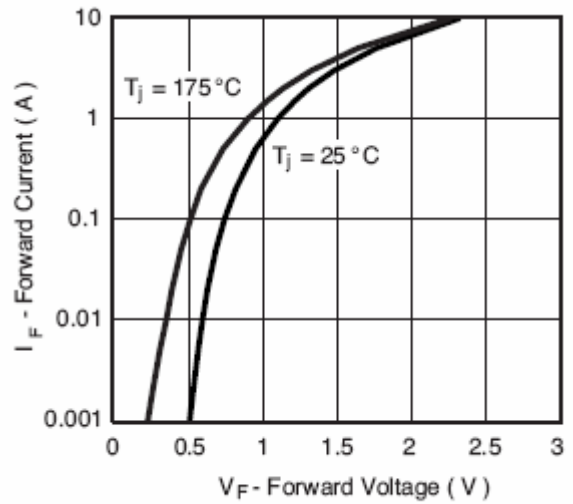

Figure 2. Forward Current vs. Forward Voltage

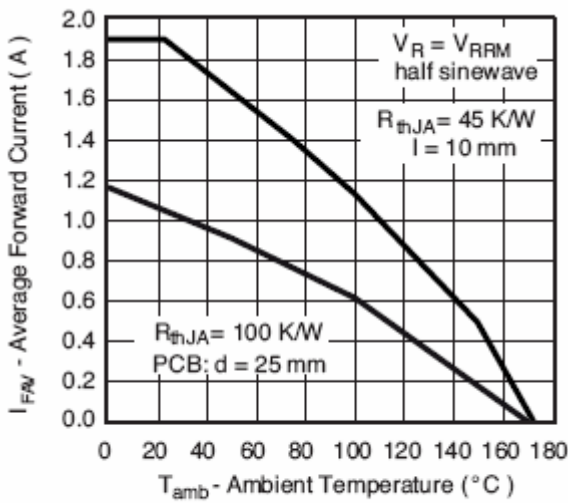

Figure 3. Max. Average Forward Current vs. Ambient Temperature

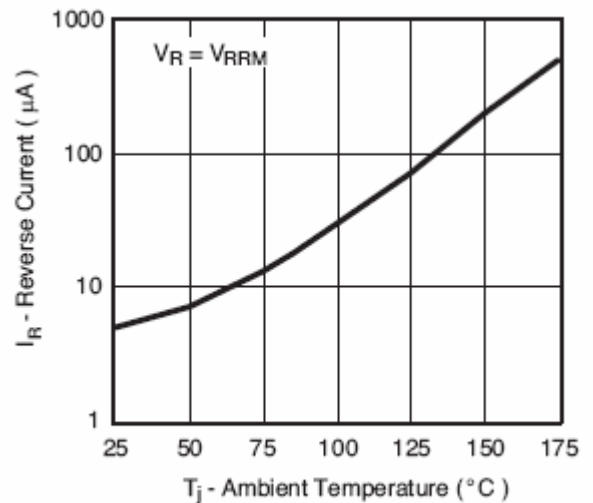

Figure 4. Reverse Current vs. Junction Temperature

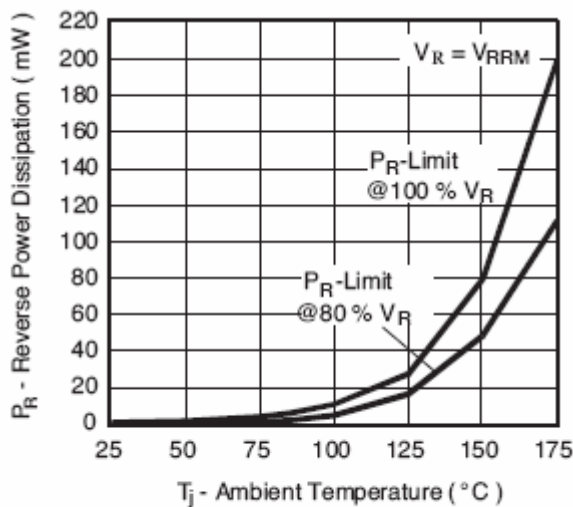

Figure 5. Max. Reverse Power Dissipation vs. Junction Temperature

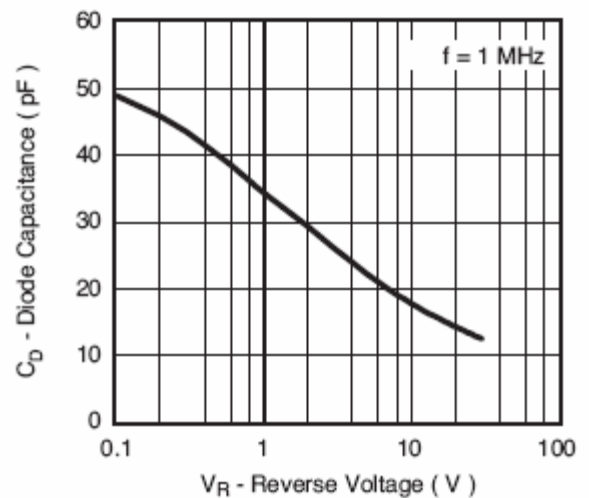

Figure 6. Diode Capacitance vs. Reverse Voltage