

# BYV26C

## SINTERED GLASS JUNCTION FAST AVALANCHE RECTIFIER

VOLTAGE: 600V

CURRENT: 1.0A



### FEATURE

- Glass passivated
- High maximum operating temperature
- Low leakage current
- Excellent stability
- Guaranteed avalanche energy absorption capability

### MECHANICAL DATA

- Case: SOD-57 sintered glass case
- Terminal: Plated axial leads solderable per MIL-STD 202E, method 208C
- Polarity: color band denotes cathode end
- Mounting position: any

### SOD-57

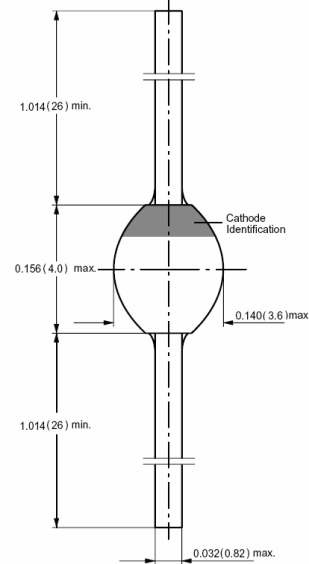

Dimensions in inches and (millimeters)

## MAXIMUM RATINGS AND ELECTRICAL CHARACTERISTICS

(single-phase, half-wave, 60HZ, resistive or inductive load rating at 25°C, unless otherwise stated)

	SYMBOL	BYV26C	units
Maximum Recurrent Peak Reverse Voltage	$V_{RRM}$	600	V
Maximum RMS Voltage	$V_{RMS}$	420	V
Maximum DC blocking Voltage	$V_{DC}$	600	V
Reverse avalanche breakdown voltage at $I_R = 0.1 \text{ mA}$	$V_{(BR)R}$	700min	V
Maximum Average Forward Rectified Current 3/8" lead length at $T_{tp} = 85^\circ\text{C}$	$I_{FAV}$	1.0	A
Non-repetitive Peak Forward Current at $t = 10\text{ms}$ half sine wave	$I_{FSM}$	30	A
Maximum Forward Voltage at rated Forward Current	$V_F$	2.5	V
Non-repetitive peak reverse avalanche energy (Note 1)	$E_{RSM}$	10	mJ
Maximum DC Reverse Current $T_a = 25^\circ\text{C}$ at rated DC blocking voltage $T_a = 165^\circ\text{C}$	$I_R$	5.0 150.0	$\mu\text{A}$ $\mu\text{A}$
Maximum Reverse Recovery Time (Note 2)	$T_{rr}$	30	nS
Diode Capacitance (Note 3)	$C_d$	45	pF
Typical Thermal Resistance (Note 4)	$R_{th(ja)}$	100	$^\circ\text{C}/\text{W}$
Storage and Operating Junction Temperature	$T_{stg}, T_j$	-65 to +175	$^\circ\text{C}$

#### Note:

- $R = 400\text{mA}$ ;  $T_j = T_{jmax}$  prior to surge; inductive load switched off
- Reverse Recovery Condition  $I_f = 0.5\text{A}$ ,  $I_r = 1.0\text{A}$ ,  $I_{rr} = 0.25\text{A}$
- Measured at 1.0 MHz and applied reverse voltage of 0Vdc
- Device mounted on an epoxy-glass printed-circuit board, 1.5mm thick; thickness of Cu-layer  $\geq 40 \mu\text{m}$

## RATINGS AND CHARACTERISTIC CURVES BYV26C

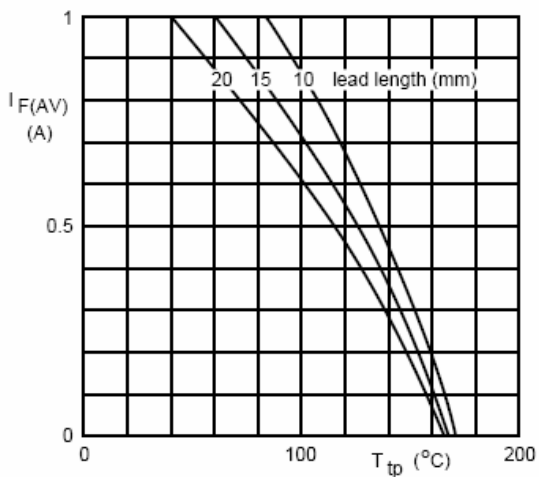

Fig.1 Maximum average forward current as a function of tie-point temperature (including losses due to reverse leakage).

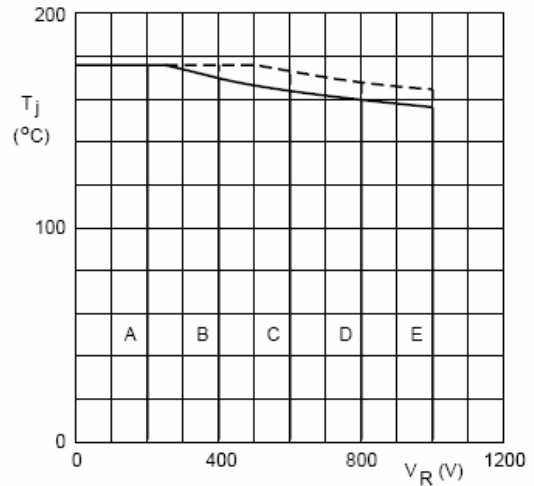

Fig.2 Maximum permissible junction temperature as a function of reverse voltage.

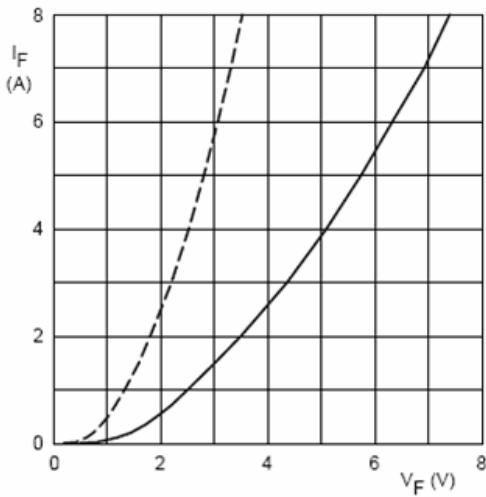

Fig.3 Forward current as a function of forward voltage; maximum values.

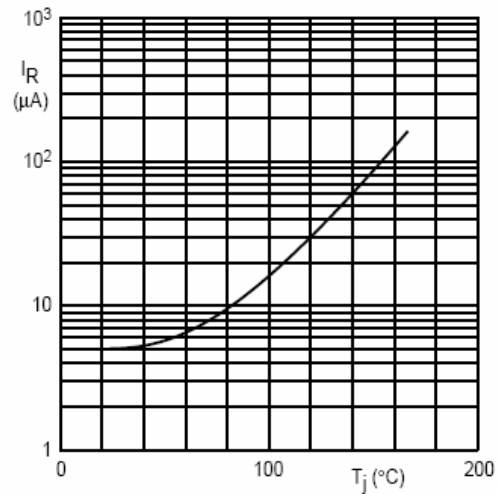

Fig.4 Reverse current as a function of junction temperature; maximum values.

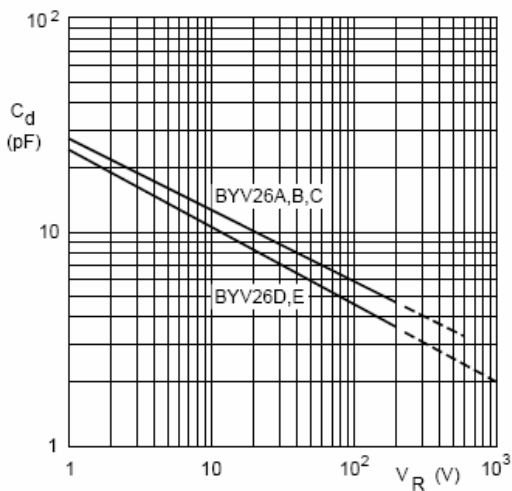

Fig.5 Diode capacitance as a function of reverse voltage, typical values.