

# BYV95C

## SINTERED GLASS JUNCTION FAST AVALANCHE RECTIFIER

VOLTAGE: 600V

CURRENT: 1.5A



### FEATURE

- Glass passivated
- High maximum operating temperature
- Low leakage current
- Excellent stability
- Guaranteed avalanche energy absorption capability

### MECHANICAL DATA

- Case: SOD-57 sintered glass case
- Terminal: Plated axial leads solderable per MIL-STD 202E, method 208C
- Polarity: color band denotes cathode end
- Mounting position: any

### SOD-57

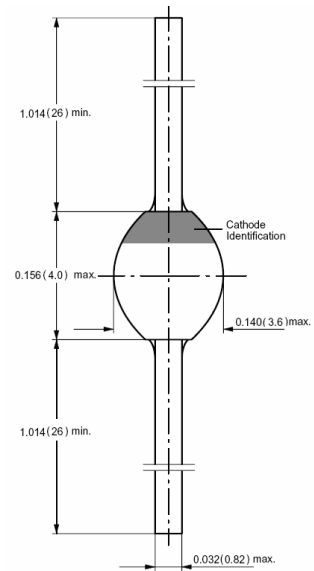

Dimensions in millimeters

## MAXIMUM RATINGS AND ELECTRICAL CHARACTERISTICS

(single-phase, half-wave, 60HZ, resistive or inductive load rating at 25°C, unless otherwise stated)

	SYMBOL	BYV95C	units
Maximum Recurrent Peak Reverse Voltage	$V_{RRM}$	600	V
Maximum RMS Voltage	$V_{RMS}$	420	V
Maximum DC blocking Voltage	$V_{DC}$	600	V
Reverse Breakdown Voltage at $I_R = 0.1mA$	$V_{(BR)R}$	700min	V
Maximum Average Forward Rectified Current 3/8"lead length at $T_a = 65^\circ C$	$I_{F(AV)}$	1.5	A
Peak Forward Surge Current 8.3ms single half sine-wave superimposed on rated load	$I_{FSM}$	35	A
Maximum Forward Voltage at $I_F = 3.0A$ and $25^\circ C$	$V_F$	1.6	V
Maximum DC Reverse Current at rated DC blocking voltage $T_j = 25^\circ C$ $T_j = 150^\circ C$	$I_R$	5.0 150	$\mu A$ $\mu A$
Maximum Reverse Recovery Time (Note 1)	$T_{rr}$	250	nS
Non Repetitive Reverse Avalanche Energy(Note 2)	$E_R$	10	mJ
Typical Junction Capacitance (Note 3)	$C_j$	45	pF
Typical Thermal Resistance (Note 4)	$R_{th(ja)}$	46	K/W
Storage and Operating Junction Temperature	$T_{stg}, T_j$	-65 to +175	$^\circ C$

Note:

- Reverse Recovery Condition  $I_F = 0.5A, I_R = 1.0A, I_{RR} = 0.25A$
- $L = 120 mH; T_j = T_j \text{ max prior to surge; inductive load switched off}$
- Measured at 1.0 MHz and applied reverse voltage of 4.0Vdc
- Thermal Resistance from Junction to Ambient at 3/8"lead length, P.C. Board Mounted

## RATINGS AND CHARACTERISTIC CURVES BYV95C

**FIG. 1 - FORWARD CURRENT DERATING CURVE**

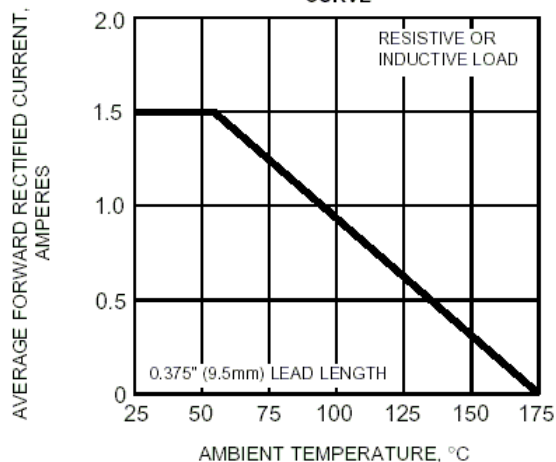

**FIG. 2 - MAXIMUM NON-REPETITIVE PEAK FORWARD SURGE CURRENT**

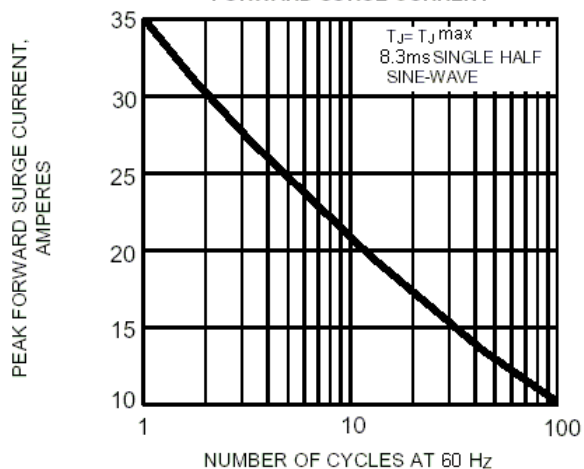

**FIG. 3 - TYPICAL INSTANTANEOUS FORWARD CHARACTERISTICS**

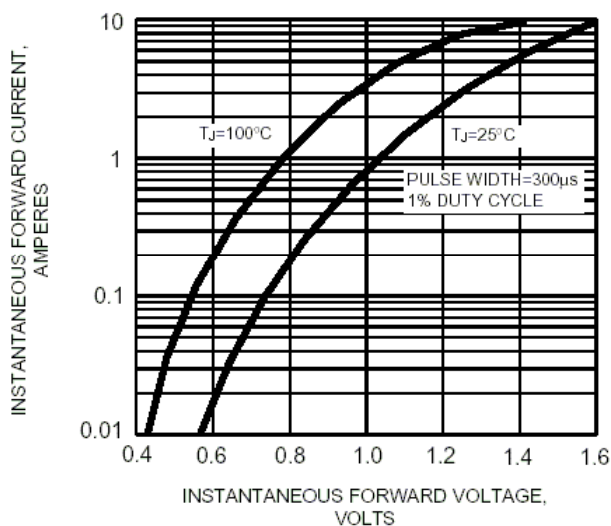

**FIG. 4 - TYPICAL REVERSE CHARACTERISTICS**

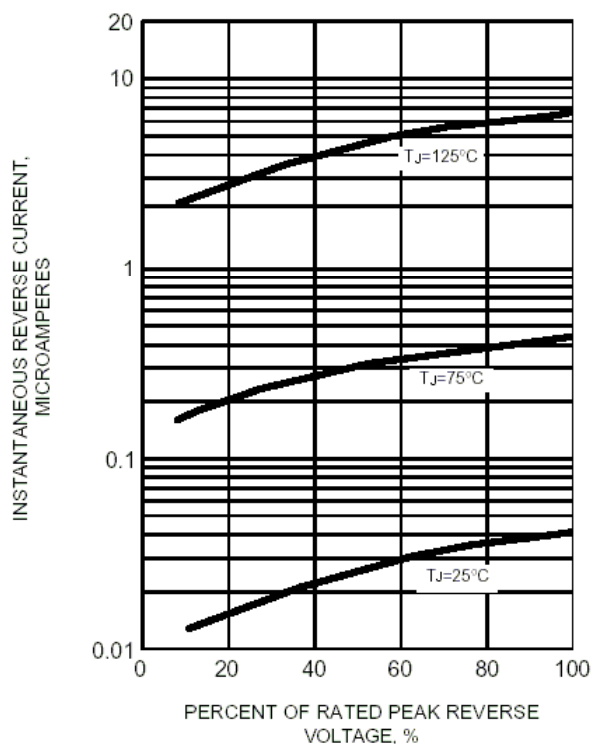

**FIG. 5 - TYPICAL JUNCTION CAPACITANCE**

