

BYV96D THRU BYV96E

SINTERED GLASS JUNCTION FAST AVALANCHE RECTIFIER

VOLTAGE: 800V to 1000V

CURRENT: 1.5A



FEATURE

Glass passivated
High maximum operating temperature
Low leakage current
Excellent stability
Guaranteed avalanche energy absorption capability

MECHANICAL DATA

Case: SOD-57 sintered glass case
Terminal: Plated axial leads solderable per MIL-STD 202E, method 208C
Polarity: color band denotes cathode end
Mounting position: any

SOD-57

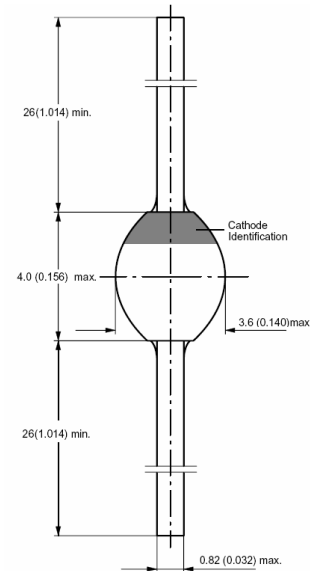

Dimensions in millimeters

MAXIMUM RATINGS AND ELECTRICAL CHARACTERISTICS

(single-phase, half-wave, 60HZ, resistive or inductive load rating at 25°C, unless otherwise stated)

	SYMBOL	BYV96D	BYV96E	units
Maximum Recurrent Peak Reverse Voltage	V_{RRM}	800	1000	V
Maximum RMS Voltage	V_{RMS}	560	700	V
Maximum DC blocking Voltage	V_{DC}	800	1000	V
Reverse Breakdown Voltage at $I_R = 0.1\text{mA}$	$V_{(BR)R}$	900min	1100min	V
Maximum Average Forward Rectified Current at $T_a = 55^\circ\text{C}$	$I_{F(AV)}$	1.5		A
Peak Forward Surge Current at 10ms single half sine-wave superimposed on rated load	I_{FSM}	35		A
Maximum Forward Voltage at rated Forward Current and 25°C $I_F = 3.0\text{A}$	V_F	1.6		V
Maximum DC Reverse Current at rated DC blocking voltage $T_j = 25^\circ\text{C}$ $T_j = 165^\circ\text{C}$	I_R	5.0 150		μA
Maximum Reverse Recovery Time (Note 1)	T_{rr}	300		nS
Non Repetitive Reverse Avalanche Energy at $L = 120\text{mH}$	E_R	10		mJ
Typical Junction Capacitance (Note 2)	C_j	10		pF
Typical Thermal Resistance (Note 3)	$R_{th(ja)}$	55		$^\circ\text{C}/\text{W}$
Storage and Operating Junction Temperature	T_{stg}, T_j	-65 to +175		$^\circ\text{C}$

Note:

- Reverse Recovery Condition $I_F = 0.5\text{A}$, $I_R = 1.0\text{A}$, $I_{RR} = 0.25\text{A}$
- Measures at 1.0MHz and applied reverse voltage of 4.0 Volts
- Thermal resistance from junction to ambient at 0.375"(9.5mm) lead length, P.C.B. mounted

Rev.A1, 13-Feb-08

<https://www.volaristech.com/>

RATINGS AND CHARACTERISTIC CURVES BYV96D THRU BYV96E

FIG. 1 - FORWARD CURRENT DERATING CURVE

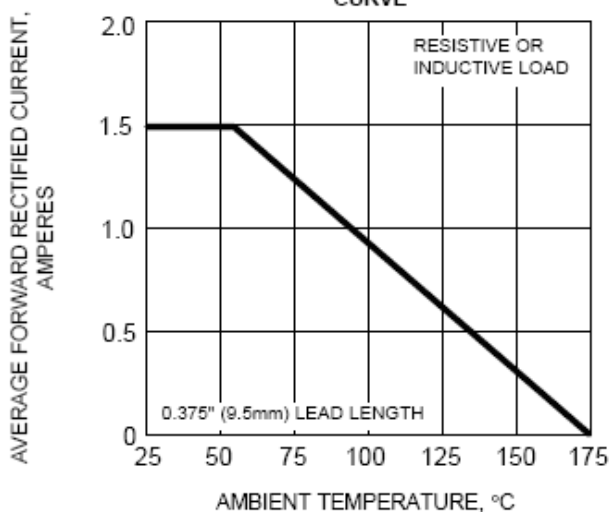

FIG. 2 - MAXIMUM NON-REPETITIVE PEAK FORWARD SURGE CURRENT

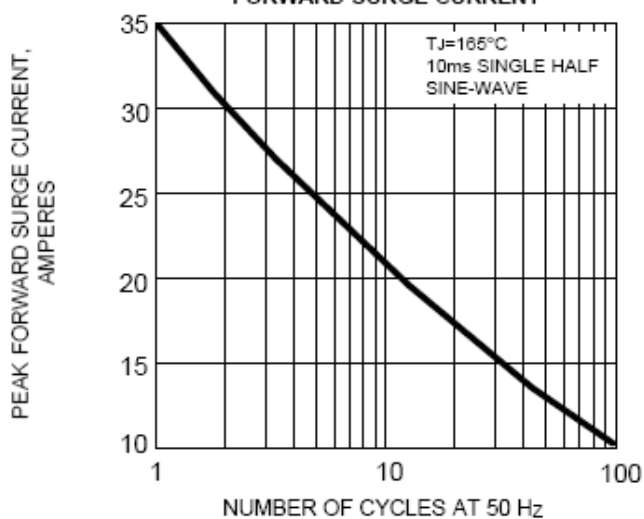

FIG. 3 - TYPICAL INSTANTANEOUS FORWARD CHARACTERISTICS

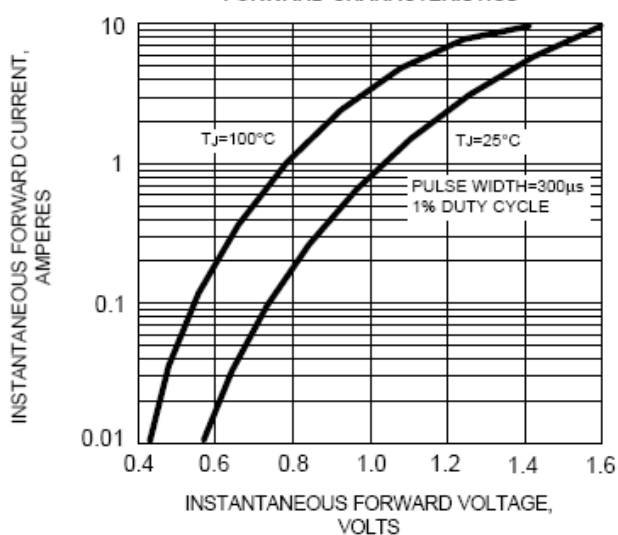

FIG. 4 - TYPICAL REVERSE CHARACTERISTICS

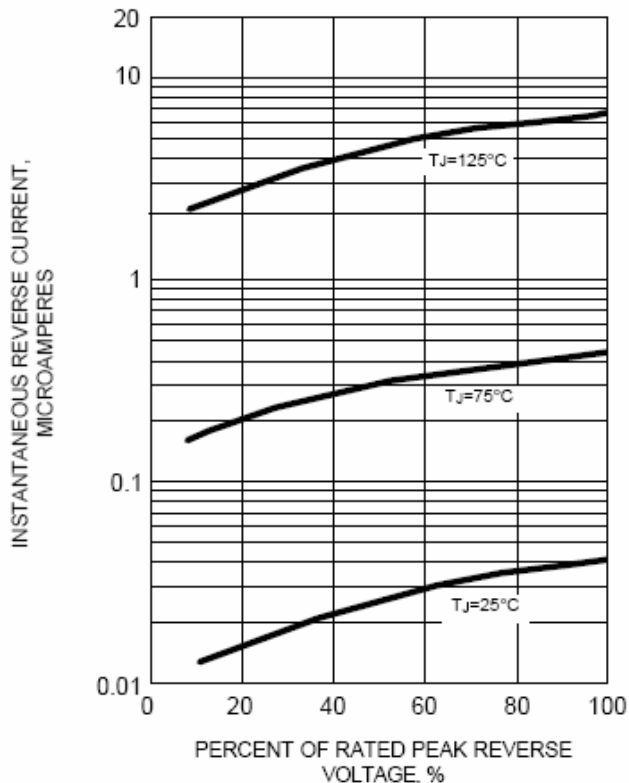

FIG. 5 - TYPICAL JUNCTION CAPACITANCE

