

## DB101 THRU DB107

### SINGLE PHASE GLASS PASSIVATED BRIDGE RECTIFIER

VOLTAGE: 50 to 1000V

CURRENT: 1.0A



#### FEATURE

Ideal for printed circuit board  
Reliable low cost construction utilizing molded plastic  
Technique  
Surge overload rating: 50 A peak

#### MECHANICAL DATA

Terminal: Plated leads solderable per J-STD-002  
Case: UL-94 Class V-0 recognized Flame Retardant Epoxy  
Polarity: Polarity symbol marked on body  
Mounting position: any

#### DB

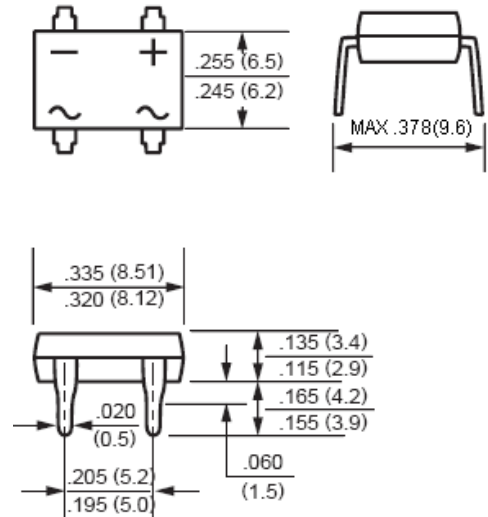

Dimensions in inches and (millimeters)

### MAXIMUM RATINGS AND ELECTRICAL CHARACTERISTICS

(single-phase, half -wave, 60HZ, resistive or inductive load rating at 25°C, unless otherwise stated)

	SYMBOL	DB 101	DB 102	DB 103	DB 104	DB 105	DB 106	DB 107	units
Maximum Recurrent Peak Reverse Voltage	V <sub>rrm</sub>	50	100	200	400	600	800	1000	V
Maximum RMS Voltage	V <sub>rms</sub>	35	70	140	280	420	560	700	V
Maximum DC blocking Voltage	V <sub>dc</sub>	50	100	200	400	600	800	1000	V
Maximum Average Forward Rectified Current at Ta =40°C	I <sub>f(av)</sub>	1.0							A
Peak Forward Surge Current 8.3ms single half sine-wave superimposed on rated load	I <sub>fsm</sub>	50.0							A
Maximum Instantaneous Forward Voltage at forward current 1.0A	V <sub>f</sub>	1.1							V
Maximum DC Reverse Current Ta =25°C at rated DC blocking voltage Ta =125°C	I <sub>r</sub>	10.0 500.0							μA μA
Typical Junction Capacitance	C <sub>j</sub>	25.0							Pf
Operating Junction Temperature Range	T <sub>j</sub>	-55 to +125							°C
Storage Temperature	T <sub>stg</sub>	-55 to +150							°C

Note:

1. Measured at 1.0 MHz and applied voltage of 4.0 volt

RATINGS AND CHARACTERISTIC CURVES DB101 THRU DB107

FIG. 1 - DERATING CURVE OUTPUT RECTIFIED CURRENT

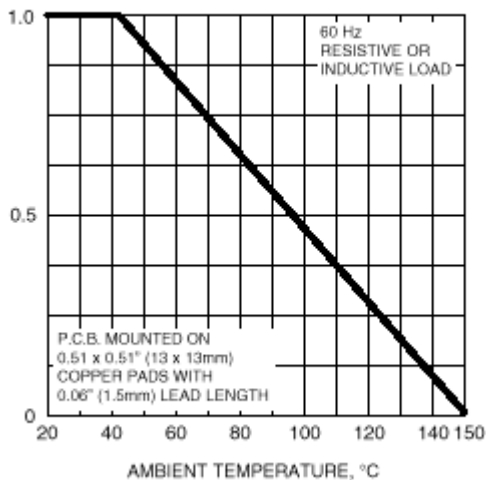

FIG. 2 - MAXIMUM NON-REPETITIVE PEAK FORWARD SURGE CURRENT PER LEG

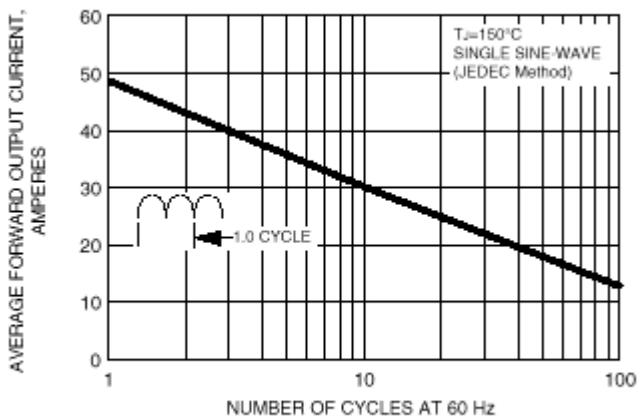

FIG. 3 - TYPICAL FORWARD CHARACTERISTICS PER LEG

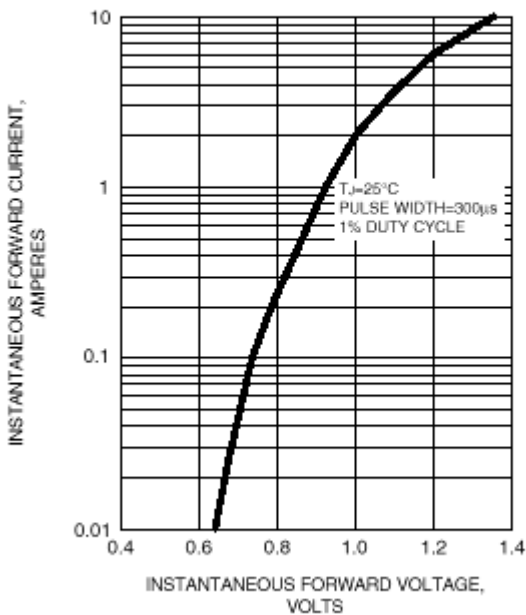

FIG. 4 - TYPICAL REVERSE LEAKAGE CHARACTERISTICS PER LEG

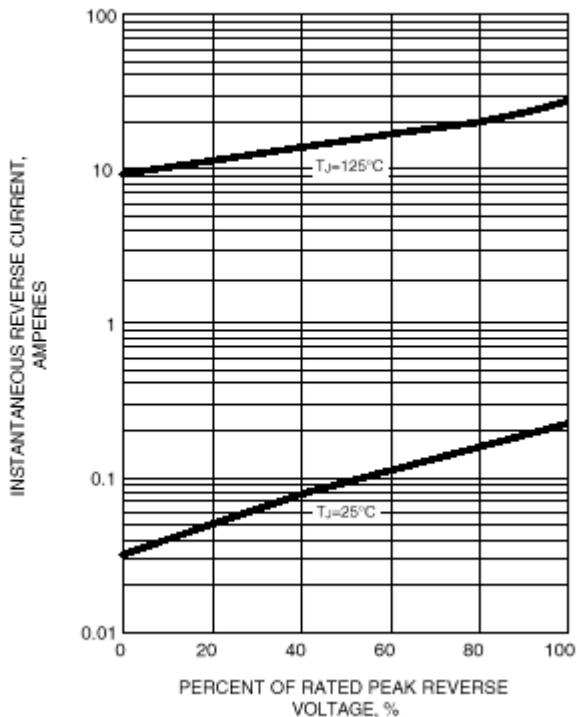

FIG. 5 - TYPICAL JUNCTION CAPACITANCE PER LEG

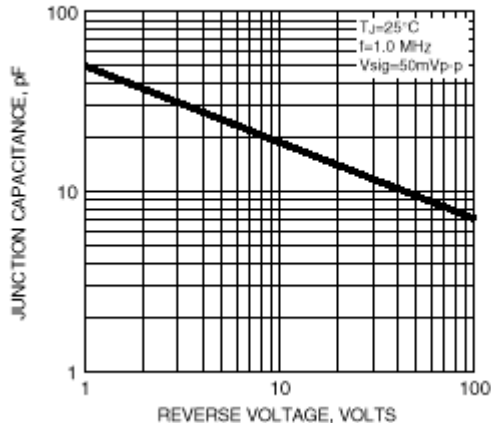

FIG. 6 - TYPICAL TRANSIENT THERMAL IMPEDANCE

