

GBPC15005 THRU GBPC1510

**SINGLE PHASE GLASS
PASSIVATED BRIDGE RECTIFIER**
VOLTAGE: 50 to 1000V CURRENT: 15.0A



FEATURE

Surge overload rating: 300 A peak
low profile design
1/4" Universal fast on terminal and
φ40 mil lead-wire available

MECHANICAL DATA

Polarity: Polarity symbol marked on body
Mounting: Hole thru for # 10 screw

GBPC/GBPCW

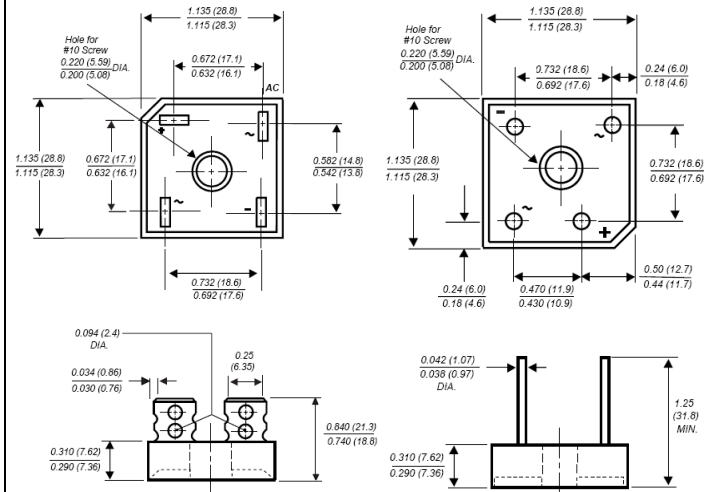

Dimensions in inches and (millimeters)

MAXIMUM RATINGS AND ELECTRICAL CHARACTERISTICS

(single-phase, half -wave, 60HZ, resistive or inductive load rating at 25°C, unless otherwise stated)

	SYMBOL	GBPC1 5005	GBPC1 501	GBPC1 502	GBPC1 504	GBPC1 506	GBPC1 508	GBPC1 510	units
Maximum Recurrent Peak Reverse Voltage	V _{rrm}	50	100	200	400	600	800	1000	V
Maximum RMS Voltage	V _{rms}	35	70	140	280	420	560	700	V
Maximum DC blocking Voltage	V _{dc}	50	100	200	400	600	800	1000	V
Maximum Average Forward Rectified Current at Ta=50°C	I _{f(av)}	15.0							A
Peak Forward Surge Current 8.3ms single half sine-wave superimposed on rated load	I _{fsm}	300.0							A
Maximum Instantaneous Forward Voltage at forward current 7.5A	V _f	1.1							V
Maximum DC Reverse Current Ta =25°C at rated DC blocking voltage Ta =100°C	I _r	10.0 500.0							μA μA
Operating Temperature Range	T _j	-55 to +125							°C
Storage and Operation Junction Temperature	T _{stg}	-55 to +150							°C

Note:
Suffix "W" for wire type

RATINGS AND CHARACTERISTIC CURVES GBPC15005 THRU GBPC1510

1

FIG. 1 - MAXIMUM OUTPUT RECTIFIED CURRENT

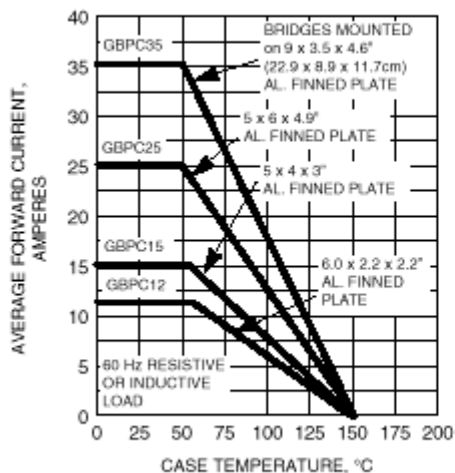

FIG. 2 - MAXIMUM OUTPUT RECTIFIED CURRENT

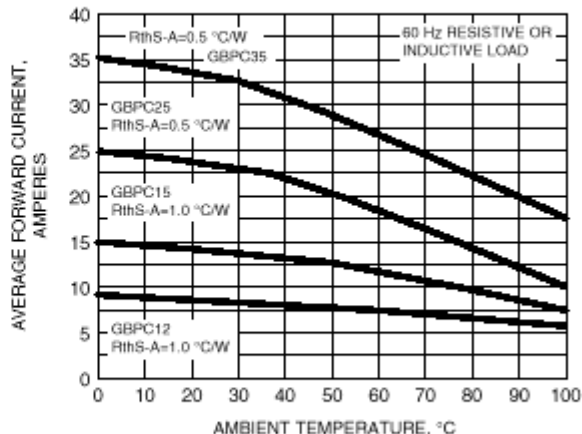

FIG. 3 - MAXIMUM POWER DESCRIPTION

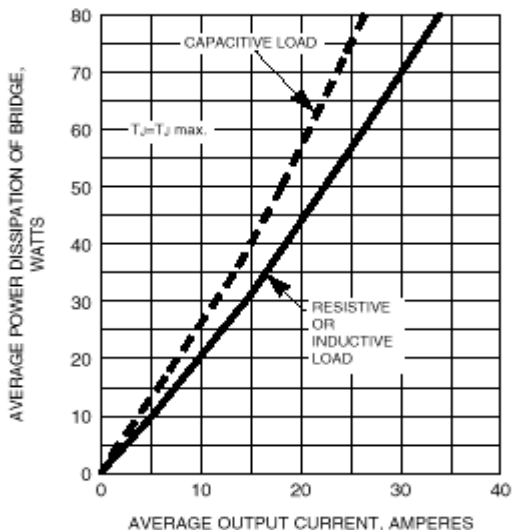

FIG. 4 - MAXIMUM NON-REPETITIVE PEAK FORWARD SURGE CURRENT PER LEG

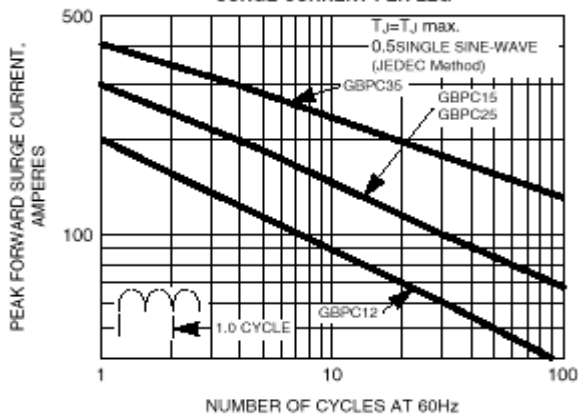

FIG. 5 - TYPICAL INSTANTANEOUS FORWARD CHARACTERISTICS PER LEG

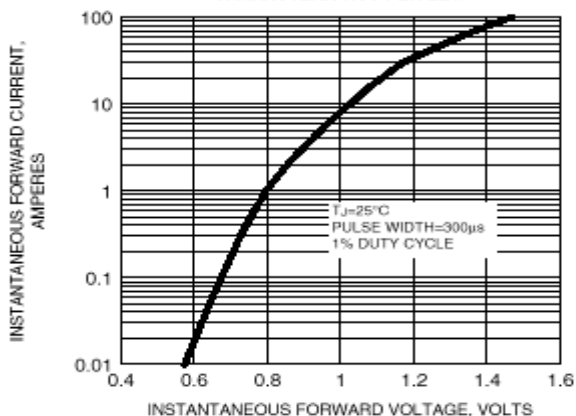

FIG. 6 - TYPICAL REVERSE LEAKAGE CHARACTERISTICS PER LEG

