

2GI1102

SINTERED GLASS JUNCTION SUPERFAST EFFICIENT RECTIFIER

VOLTAGE: 100V

CURRENT: 2.0A



FEATURE

- Glass passivated
- Superfast recovery time for high efficiency
- Low forward voltage, high current capability
- Low leakage
- High surge capability

MECHANICAL DATA

- Case: SOD-57 sintered glass case
- Terminal: Plated axial leads solderable per MIL-STD 202E, method 208C
- Polarity: color band denotes cathode end
- Mounting position: any

SOD-57

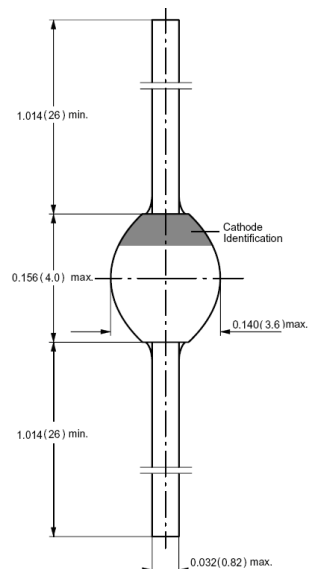

Dimensions in inches and (millimeters)

MAXIMUM RATINGS AND ELECTRICAL CHARACTERISTICS

(single-phase, half-wave, 60HZ, resistive or inductive load rating at 25°C, unless otherwise stated)

	SYMBOL	G11102	units
Maximum Recurrent Peak Reverse Voltage	V_{RRM}	100	V
Maximum RMS Voltage	V_{RMS}	70	V
Maximum DC blocking Voltage	V_{DC}	100	V
Maximum Average Forward Rectified Current 3/8" lead length at $T_a=55^\circ C$	I_{FAV}	2.5	A
Peak Forward Surge Current 8.3ms single half sine-wave superimposed on rated load	I_{FSM}	50	A
Maximum Forward Voltage at Forward Current 2.0A and 25°C	V_F	0.975	V
Maximum DC Reverse Current at $T_a=25^\circ C$ At rated DC Blocking Voltage $T_a=100^\circ C$	I_R	2.0 50	μA
Maximum Reverse Recovery Time (Note 1)	T_{rr}	25	nS
Typical Junction Capacitance (Note 2)	C_j	45.0	pF
Typical Thermal Resistance (Note 3)	$R_{th}(ja)$	65.0	$^\circ C/W$
Storage and Operating Junction Temperature	T_{stg}, T_j	-65 to +175	$^\circ C$

- Note:
- Reverse Recovery Condition $I_f = 0.5A, I_r = 1.0A, I_{rr} = 0.25A$
 - Measured at 1.0 MHz and applied reverse voltage of 4.0Vdc
 - Thermal Resistance from Junction to Ambient at 3/8" lead length and mounted on P.C. B. with 0.5×0.5" copper pads

RATINGS AND CHARACTERISTIC CURVES GI1102

FIG. 1 - MAXIMUM FORWARD CURRENT DERATING CURVE

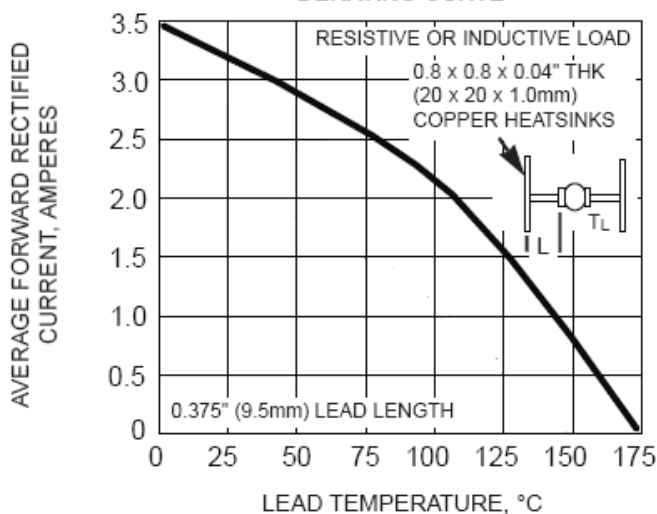

FIG. 2 - MAXIMUM NON-REPETITIVE PEAK FORWARD SURGE CURRENT

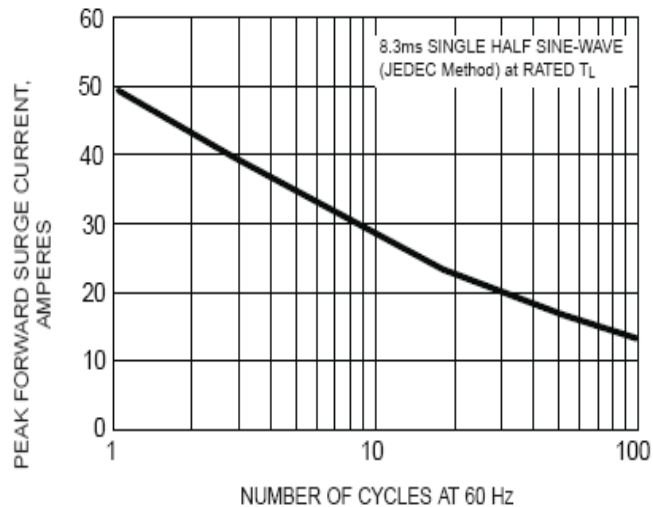

FIG. 3 - TYPICAL INSTANTANEOUS FORWARD CHARACTERISTICS

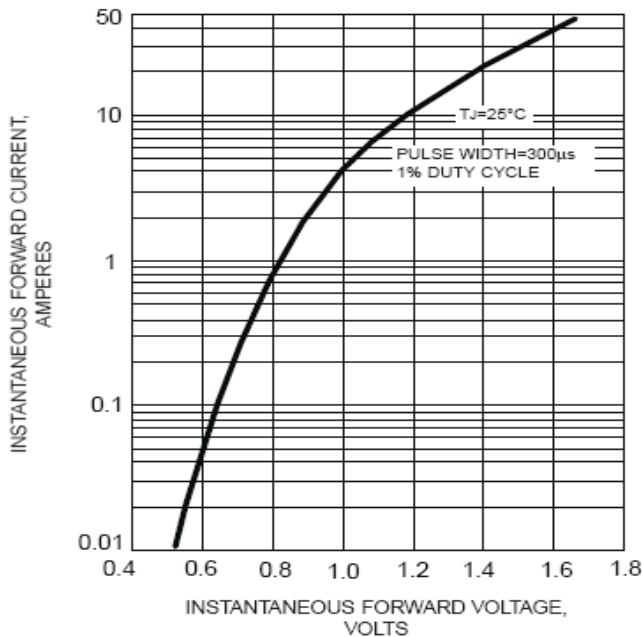

FIG. 4 - TYPICAL REVERSE LEAKAGE CHARACTERISTICS

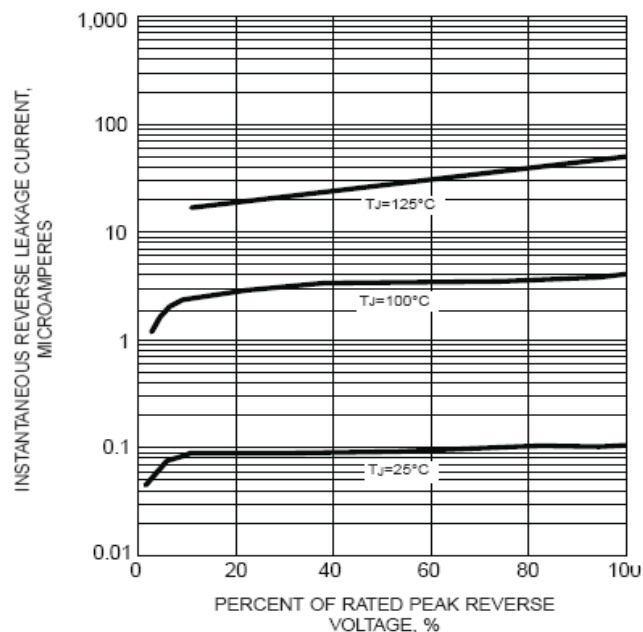

FIG. 5 - TYPICAL JUNCTION CAPACITANCE

