

KBPC1005 THRU KBPC110

SINGLE PHASE SILICON BRIDGE RECTIFIER

VOLTAGE: 50 to 1000V

CURRENT: 3.0A



FEATURE

Ideal for printed circuit board
Surge overload rating: 50 A peak
High case dielectric strength

MECHANICAL DATA

Terminal: Plated leads solderable per J-STD-002
Case: UL-94 Class V-0 recognized Flame Retardant Epoxy
Polarity: Polarity symbol marked on body
Mounting: Hole thru for #6 screw

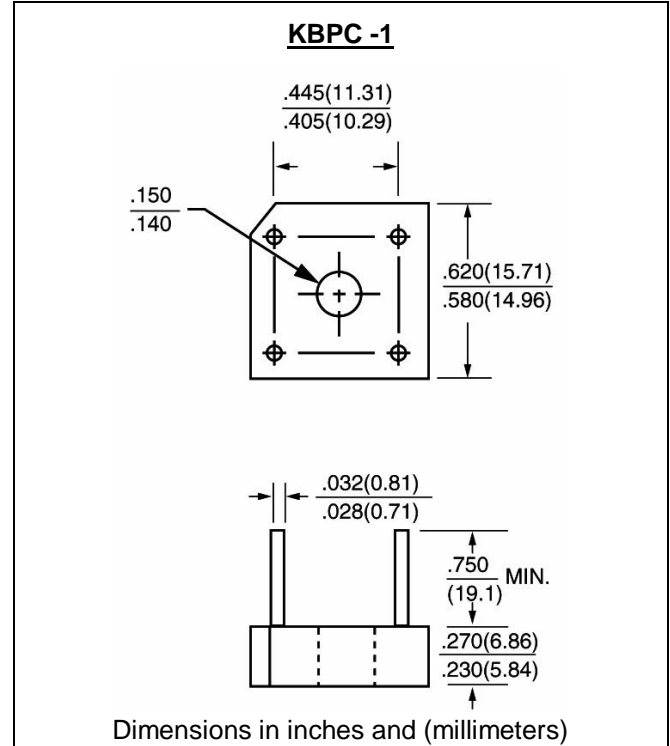

MAXIMUM RATINGS AND ELECTRICAL CHARACTERISTICS

(single-phase, half -wave, 60HZ, resistive or inductive load rating at 25°C, unless otherwise stated)

	SYMBOL	KBPC 1005	KBPC 101	KBPC 102	KBPC 104	KBPC 106	KBPC 108	KBPC 110	units
Maximum Recurrent Peak Reverse Voltage	V _{rrm}	50	100	200	400	600	800	1000	V
Maximum RMS Voltage	V _{rms}	35	70	140	280	420	560	700	V
Maximum DC blocking Voltage	V _{dc}	50	100	200	400	600	800	1000	V
Maximum Average Forward Rectified Current at T _c = 50°C	I _{f(av)}	3.0							A
Peak Forward Surge Current 8.3ms single Half sine-wave superimposed on rated load	I _{fsm}	50.0							A
Maximum Instantaneous Forward Voltage at Forward current 1.5A DC	V _f	1.1							V
Maximum DC Reverse Current Ta = 25°C at rated DC blocking voltage Ta = 100°C	I _r	10.0 1.0							μA mA
Operating Temperature Range	T _j	-55 to +125							°C
Storage and Operation Junction Temperature	T _{stg}	-55 to +150							°C

RATINGS AND CHARACTERISTIC CURVES KBPC1005 THRU KBPC110

FIG. 1 - MAXIMUM NON-REPETITIVE FORWARD SURGE CURRENT

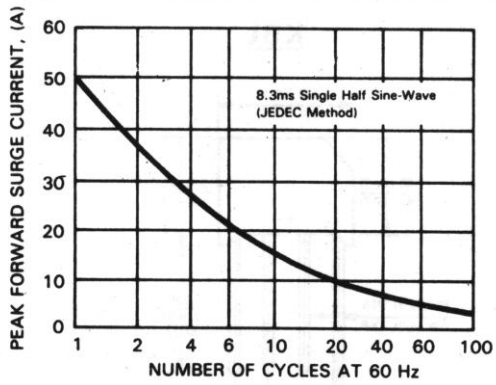

FIG. 2 - TYPICAL FORWARD CURRENT DERATING CURVE

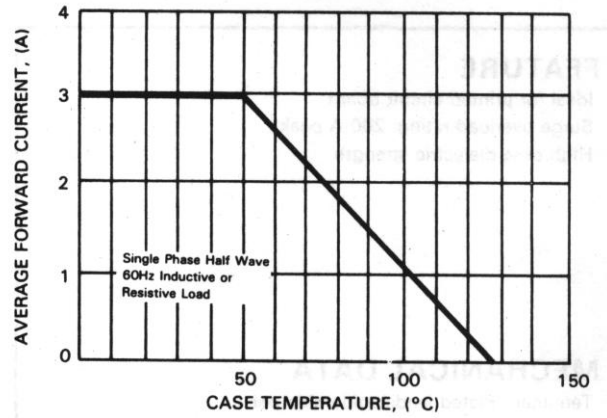

FIG. 3 - TYPICAL INSTANTANEOUS FORWARD CHARACTERISTICS

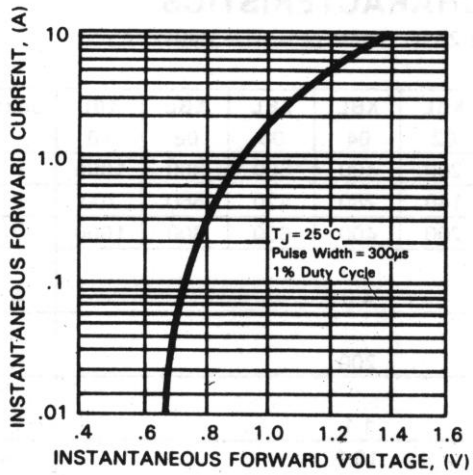

FIG. 4 - TYPICAL REVERSE CHARACTERISTICS

