

KBU6AG THRU KBU6MG

SINGLE-PHASE GLASS PASSIVATED SILICON BRIDGE RECTIFIER

VOLTAGE: 50 to 1000V

CURRENT: 6.0A



FEATURE

Ideal for printed circuit board
Surge overload rating: 150 A peak
High case dielectric strength

MECHANICAL DATA

Terminal: Plated leads solderable per J-STD-002
Case: UL-94 Class V-0 recognized Flame Retardant Epoxy
Polarity: Polarity symbol marked on body
Mounting position: any

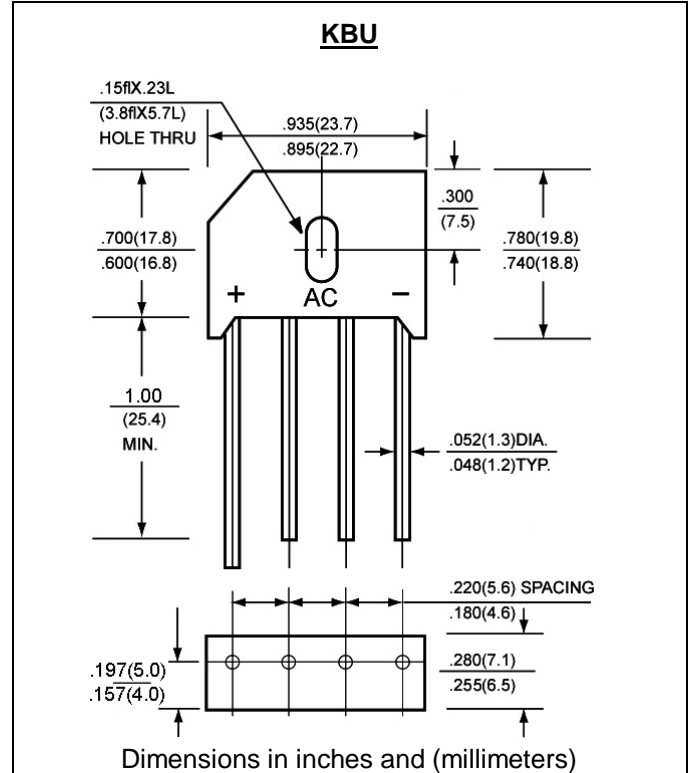

MAXIMUM RATINGS AND ELECTRICAL CHARACTERISTICS

(single-phase, half -wave, 60HZ, resistive or inductive load rating at 25°C, unless otherwise stated)

	SYMBOL	KBU 6AG	KBU 6BG	KBU 6DG	KBU 6GG	KBU 6JG	KBU 6KG	KBU 6MG	units
Maximum Recurrent Peak Reverse Voltage	V _{rrm}	50	100	200	400	600	800	1000	V
Maximum RMS Voltage	V _{rms}	35	70	140	280	420	560	700	V
Maximum DC blocking Voltage	V _{dc}	50	100	200	400	600	800	1000	V
Maximum Average Forward Rectified Current at T _c =75°C	I _{f(av)}	6.0							A
Peak Forward Surge Current 8.3ms single half sine-wave superimposed on rated load	I _{fsm}	150.0							A
Maximum Instantaneous Forward Voltage at forward current 3.0A	V _f	1.1							V
Maximum DC Reverse Current Ta =25°C at rated DC blocking voltage Ta =125°C	I _r	10.0 1.0							μA mA
Operating Temperature Range	T _j	-55 to +150							°C
Storage and Operation Junction Temperature	T _{stg}	-55 to +150							°C

RATINGS AND CHARACTERISTIC CURVES KBU6AG THRU KBU6MG

FIG. 1 - MAXIMUM NON-REPETITIVE FORWARD SURGE CURRENT

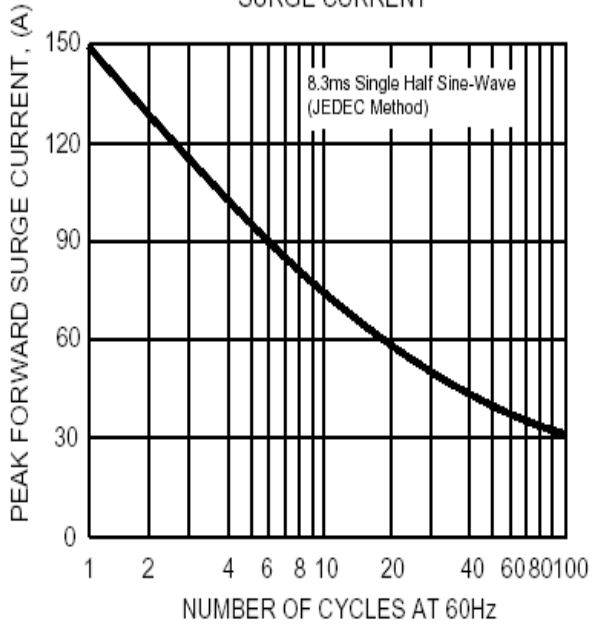

FIG. 2 - TYPICAL FORWARD CURRENT DERATING CURVE

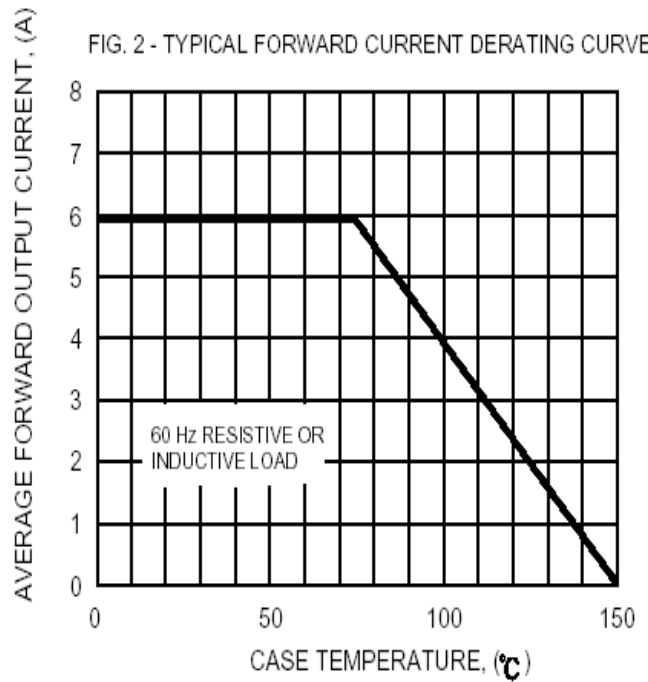

FIG. 3- TYPICAL INSTANTANEOUS FORWARD CHARACTERISTICS

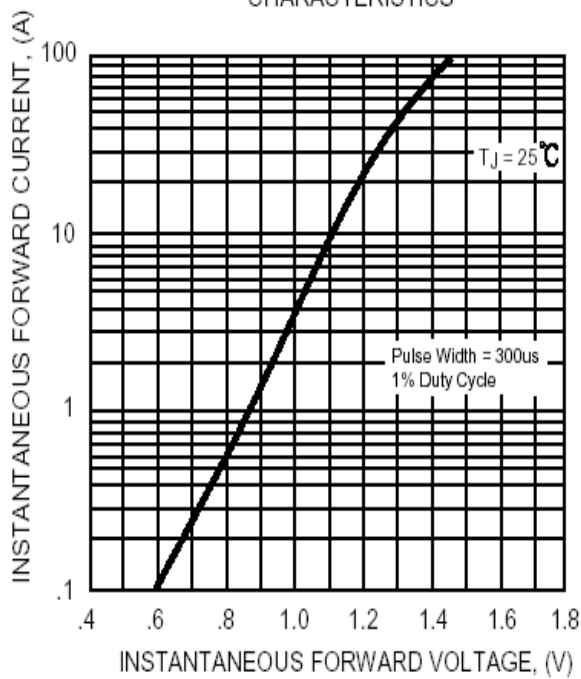

FIG. 4 - TYPICAL REVERSE CHARACTERISTICS

