

# SSF3DG-S28-E

## GLASS PASSIVATED JUNCTION ULTRAFAST EFFICIENT RECTIFIER

VOLTAGE: 200V(Surge: 280V)

CURRENT:3.0A



### FEATURE

Low power loss  
High surge capability  
Ultra-fast recovery time for high efficiency  
Glass passivated chip junction  
High temperature soldering guaranteed  
250°C/10sec/0.375"lead length at 5 lbs tension  
Halogen Free

### MECHANICAL DATA

Terminal: Plated axial leads solderable per MIL-STD 202E, method 208C  
Case: Molded with UL-94 Class V-0 recognized Halogen Free Epoxy  
Polarity: color band denotes cathode  
Weight: 0.045 oz., 1.2 g  
Marking: SSF3DGS

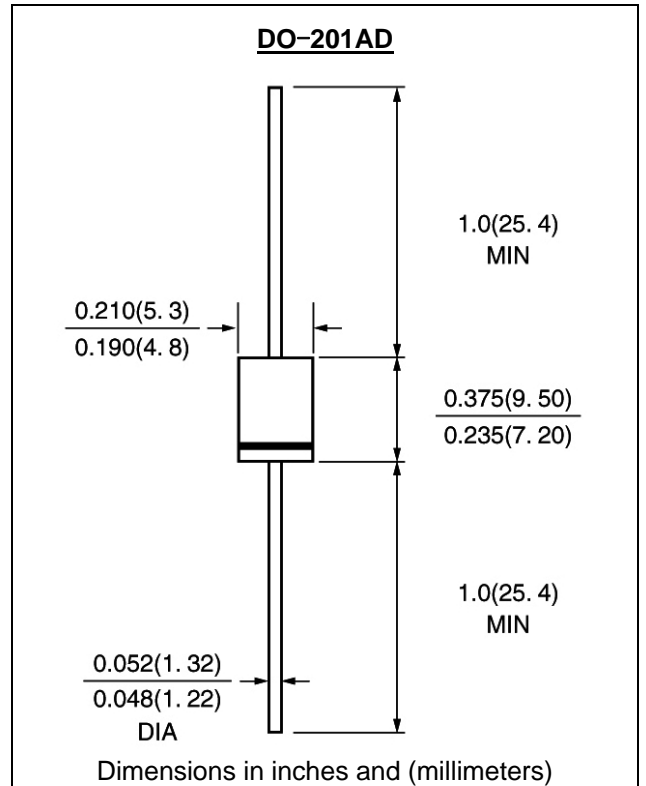

### MAXIMUM RATINGS AND ELECTRICAL CHARACTERISTICS

(single-phase, half-wave, 60Hz, resistive or inductive load rating at 25°C, unless otherwise stated)

	Symbol	SSF3DG-S28-E	units
Maximum Recurrent Peak Reverse Voltage	V <sub>rrm</sub>	280	V
Maximum RMS Voltage	V <sub>rms</sub>	140	V
Maximum DC blocking Voltage	V <sub>dc</sub>	200	V
Maximum Average Forward Rectified Current 3/8"lead length at Ta =55°C	I <sub>f(av)</sub>	3.0	A
Peak Forward Surge Current 8.3ms single half sine-wave superimposed on rated load	I <sub>fsm</sub>	125	A
Maximum Forward Voltage at Forward Current 3.0A	V <sub>f</sub>	0.95	V
Maximum DC Reverse Current Ta =25°C at rated DC blocking voltage Ta=125°C	I <sub>r</sub>	10 100	μA
Maximum Reverse Recovery Time (Note 1)	T <sub>rr</sub>	35	nS
Typical thermal resistance junction to ambient	R <sub>th(ja)</sub>	20	°C/W
Storage and Operating Temperature Range	T <sub>stg</sub> , T <sub>j</sub>	-55 to +175	°C

Note:

- Reverse Recovery Condition I<sub>f</sub> =0.5A, I<sub>r</sub> =1.0A, I<sub>rr</sub> =0.25A

## RATINGS AND CHARACTERISTIC CURVES SSF3DG-S28-E

Figure 1. Maximum Forward Current Derating Curve

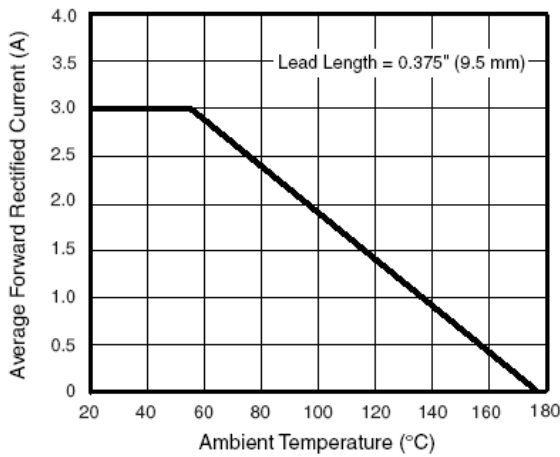

Figure 2. Maximum Non-Repetitive Peak Forward Surge Current

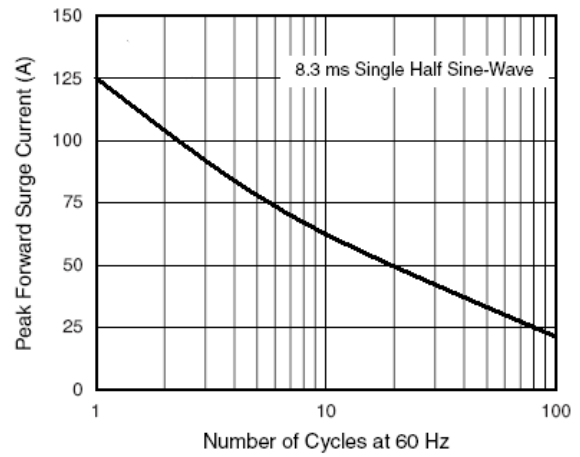

Figure 3. Typical Instantaneous Forward Characteristics

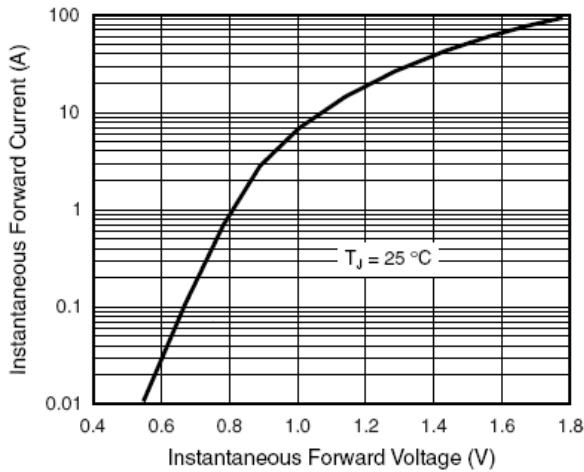

Figure 4. Typical Reverse Leakage Characteristics

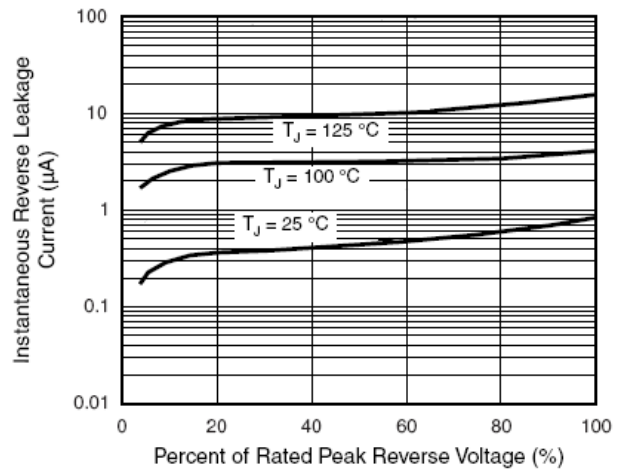

Figure 5. Typical Junction Capacitance

