

# UG2KB05-E THRU UG2KB100-E

## SINGLE PHASE GLASS PASSIVATED BRIDGE RECTIFIER

Voltage: 50 to 1000V

Current: 2.0A



### Features

Glass passivated chip junction  
High case dielectric strength  
High surge current capability  
Ideal for printed circuit board  
This series is UL listed under Recognized Component Index, file number E330278  
Halogen Free

### Mechanical Data

Terminal: Plated leads solderable per J-STD-002  
Case: UL-94 Class V-0 recognized Halogen Free Epoxy  
Polarity: Polarity symbol marked on body  
Mounting position: any

### D3K

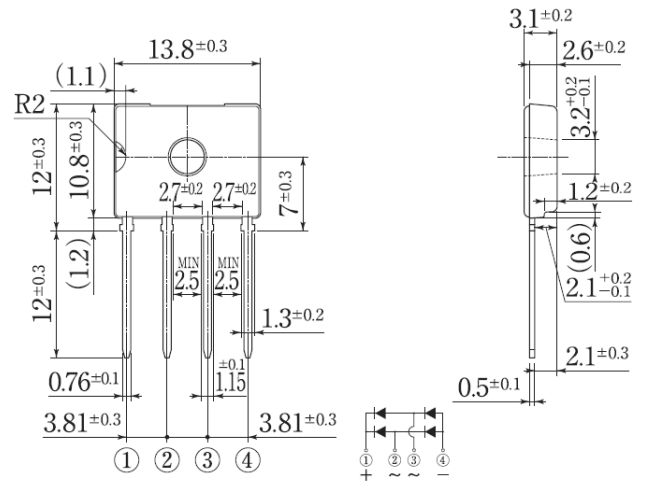

Dimensions in millimeters

### MAXIMUM RATINGS AND ELECTRICAL CHARACTERISTICS

(single-phase, half -wave, 60HZ, resistive or inductive load rating at 25°C, unless otherwise stated)

	Symbol	UG2K B05 -E	UG2 KB10 -E	UG2 KB20 -E	UG2 KB40 -E	UG2K B60 -E	UG2 KB80 -E	UG2K B100 -E	units
Maximum repetitive peak reverse voltage	V <sub>rrm</sub>	50	100	200	400	600	800	1000	V
Maximum RMS voltage	V <sub>rms</sub>	35	70	140	280	420	560	700	V
Maximum DC blocking voltage	V <sub>dc</sub>	50	100	200	400	600	800	1000	V
Maximum average forward rectified output current T <sub>c</sub> 143°C with heatsink	I <sub>f(av)</sub>	2.0							A
Peak forward surge current single sine-wave superimposed on rated load (JEDEC Method)	I <sub>fsm</sub>	62							A
Maximum instantaneous forward voltage drop per leg at 1.0A	V <sub>f</sub>	1.05							V
Rating for fusing (3ms ≤ t < 8.3ms)	I <sup>2</sup> t	16							A <sup>2</sup> Sec
Maximum DC reverse current at rated DC blocking voltage per leg	I <sub>r</sub>	10.0 500							μA
Thermal resistance	R <sub>th(ja)</sub> R <sub>th(jc)</sub> R <sub>th(jl)</sub>	55 1.5 15							°C/W
Operating junction and storage temperature range	T <sub>j</sub> , T <sub>stg</sub>	-55 to +150							°C

Note:

## RATINGS AND CHARACTERISTIC CURVES UG2KB05-E THRU UG2KB100-E

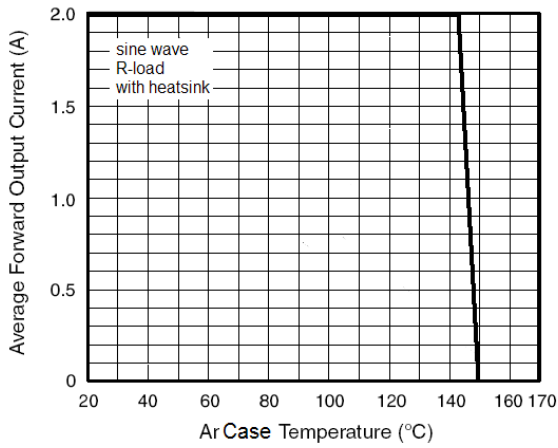

Figure 1. Derating Curve Output Rectified Current

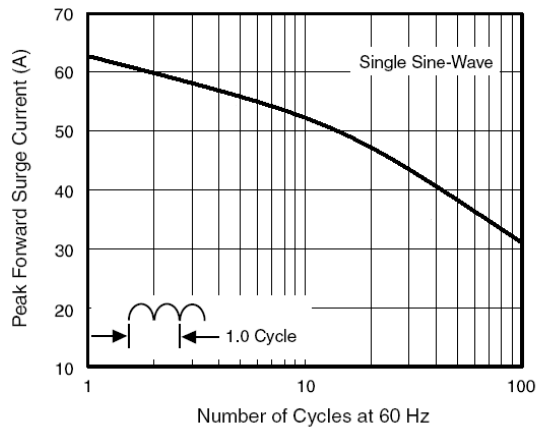

Figure 2. Maximum Non-Repetitive Peak Forward Surge Current Per Diode

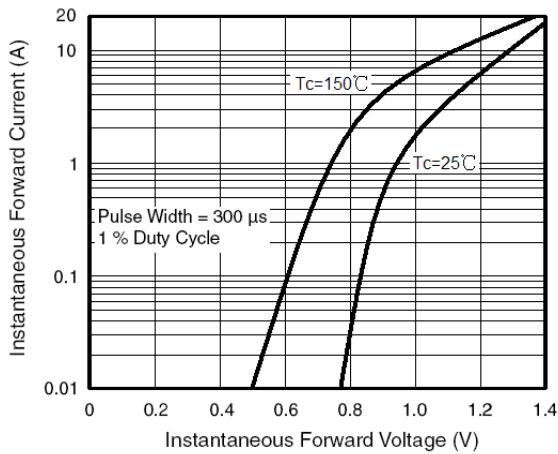

Figure 3. Typical Forward Characteristics Per Diode

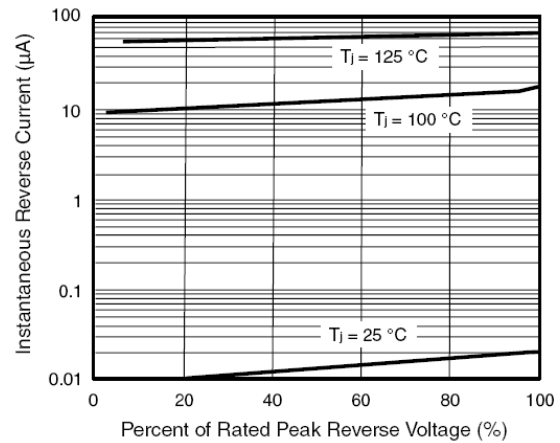

Figure 4. Typical Reverse Leakage Characteristics Per Diode

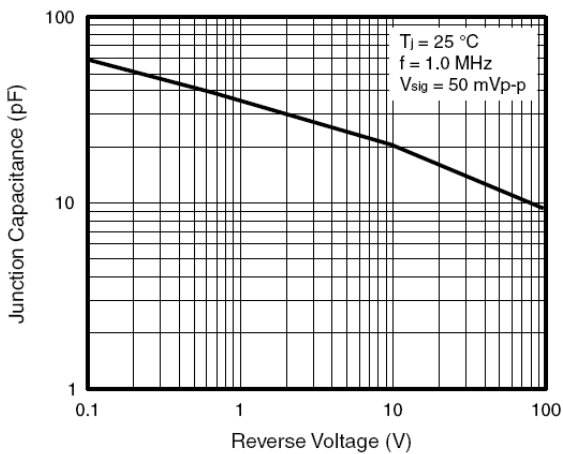

Figure 5. Typical Junction Capacitance Per Diode