

UR2KB05 THRU UR2KB100

SINGLE PHASE GLASS PASSIVATED BRIDGE RECTIFIER

Voltage: 50 to 1000V

Current: 2.0A



Features

Glass passivated chip junction
High case dielectric strength
High surge current capability
Ideal for printed circuit board

Mechanical Data

Terminal: Plated leads solderable per J-STD-002
Case: UL-94 Class V-0 recognized Flame Retardant Epoxy
Polarity: Polarity symbol marked on body
Mounting position: any

D3K

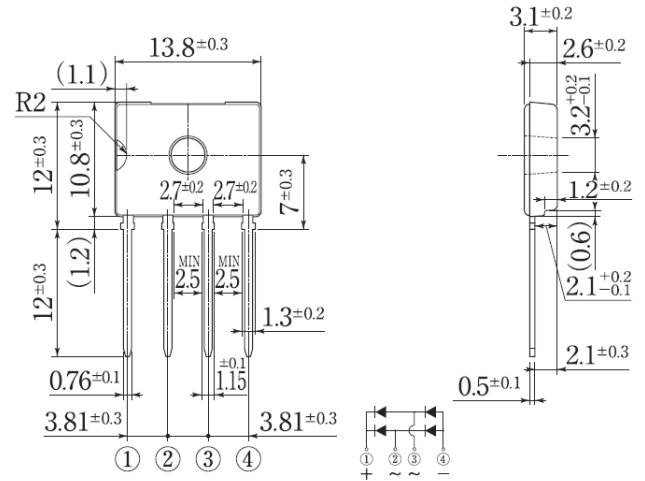

Dimensions in millimeters

MAXIMUM RATINGS AND ELECTRICAL CHARACTERISTICS

(single-phase, half -wave, 60HZ, resistive or inductive load rating at 25°C, unless otherwise stated)

	Symbol	UR2K B05	UR2K B10	UR2K B20	UR2K B40	UR2K B60	UR2K B80	UR2K B100	units
Maximum repetitive peak reverse voltage	V _{rrm}	50	100	200	400	600	800	1000	V
Maximum RMS voltage	V _{rms}	35	70	140	280	420	560	700	V
Maximum DC blocking voltage	V _{dc}	50	100	200	400	600	800	1000	V
Maximum average forward rectified output current T _c 143°C with heatsink	I _{f(av)}	2.0							A
Peak forward surge current single sine-wave superimposed on rated load (JEDEC Method)	I _{fsm}	62							A
Maximum instantaneous forward voltage drop per leg at 1.0A	V _f	1.05							V
Rating for fusing (3ms ≤ t < 8.3ms)	I ² t	16							A ² Sec
Maximum DC reverse current at rated DC blocking voltage per leg	I _r	10.0 500							μA
Thermal resistance	R _{th(ja)} R _{th(jc)} R _{th(jl)}	55 1.5 15							°C/W
Operating junction and storage temperature range	T _j , T _{stg}	-55 to +150							°C

Note:

RATINGS AND CHARACTERISTIC CURVES UR2KB05 THRU UR2KB100

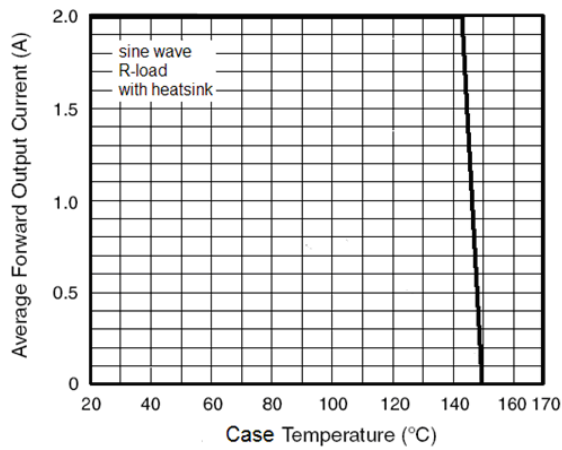

Figure 1. Derating Curve Output Rectified Current

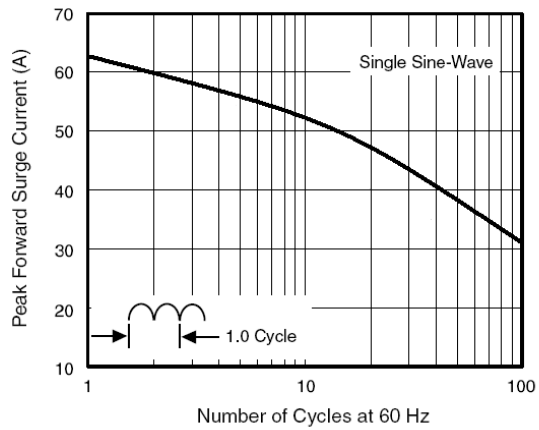

Figure 2. Maximum Non-Repetitive Peak Forward Surge Current Per Diode

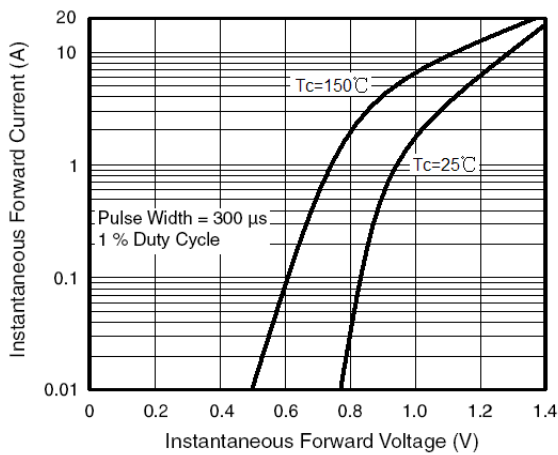

Figure 3. Typical Forward Characteristics Per Diode

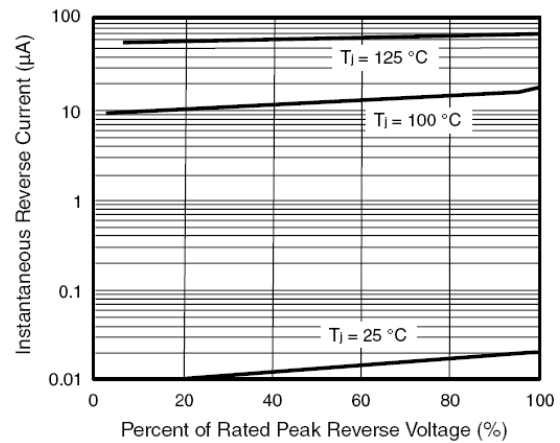

Figure 4. Typical Reverse Leakage Characteristics Per Diode

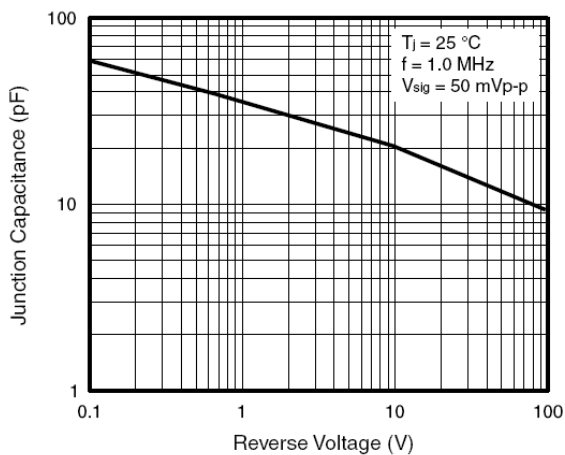

Figure 5. Typical Junction Capacitance Per Diode